

portfolio

walking on a dream...

Koduri Nagasrivatsa

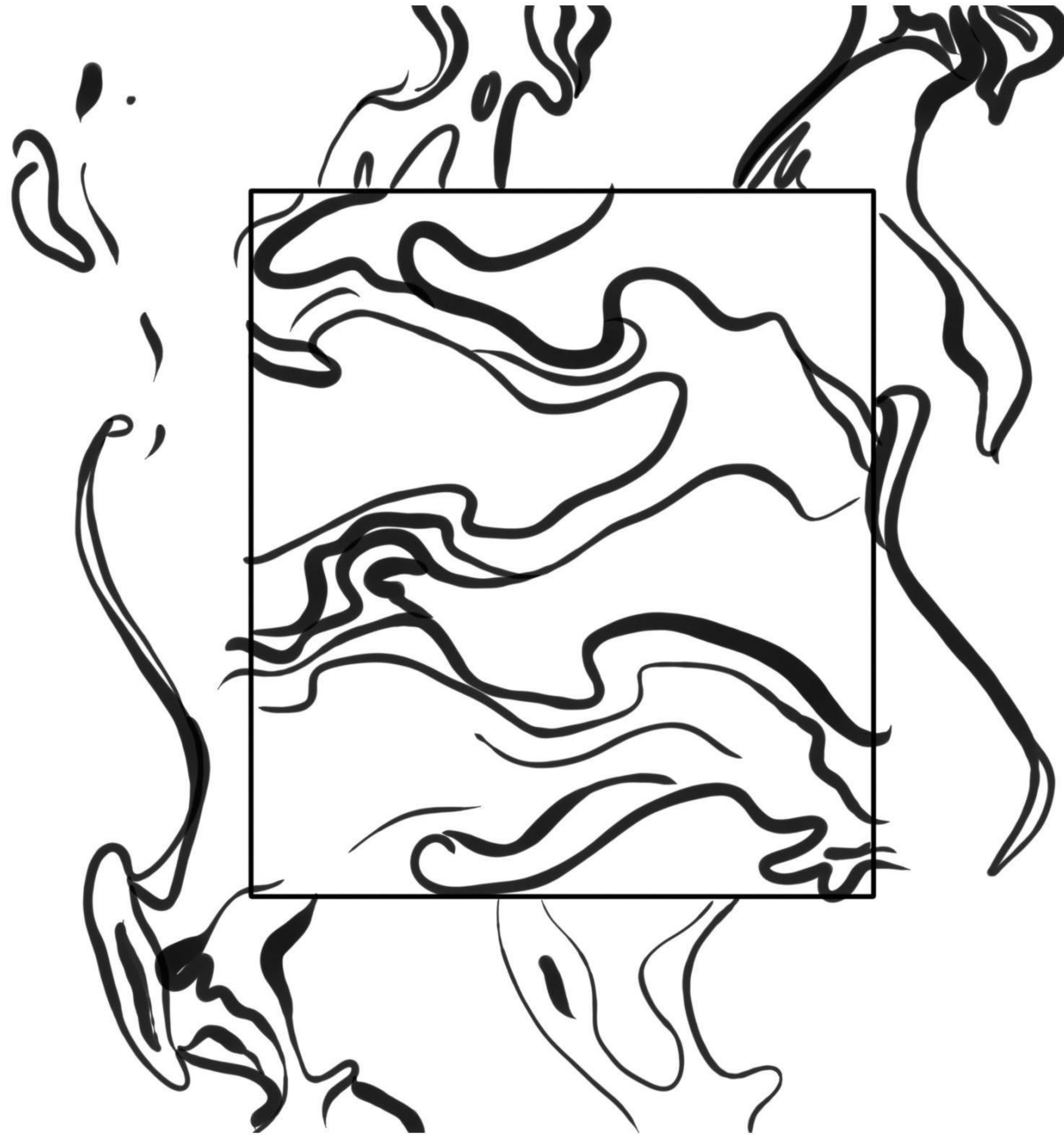

“The word “show” suggests that you’re revealing something. It doesn’t suggest finding. And because I do what I do every day, I have to make sure that the showing of things is in itself the seeking for things.”

Es Devlin

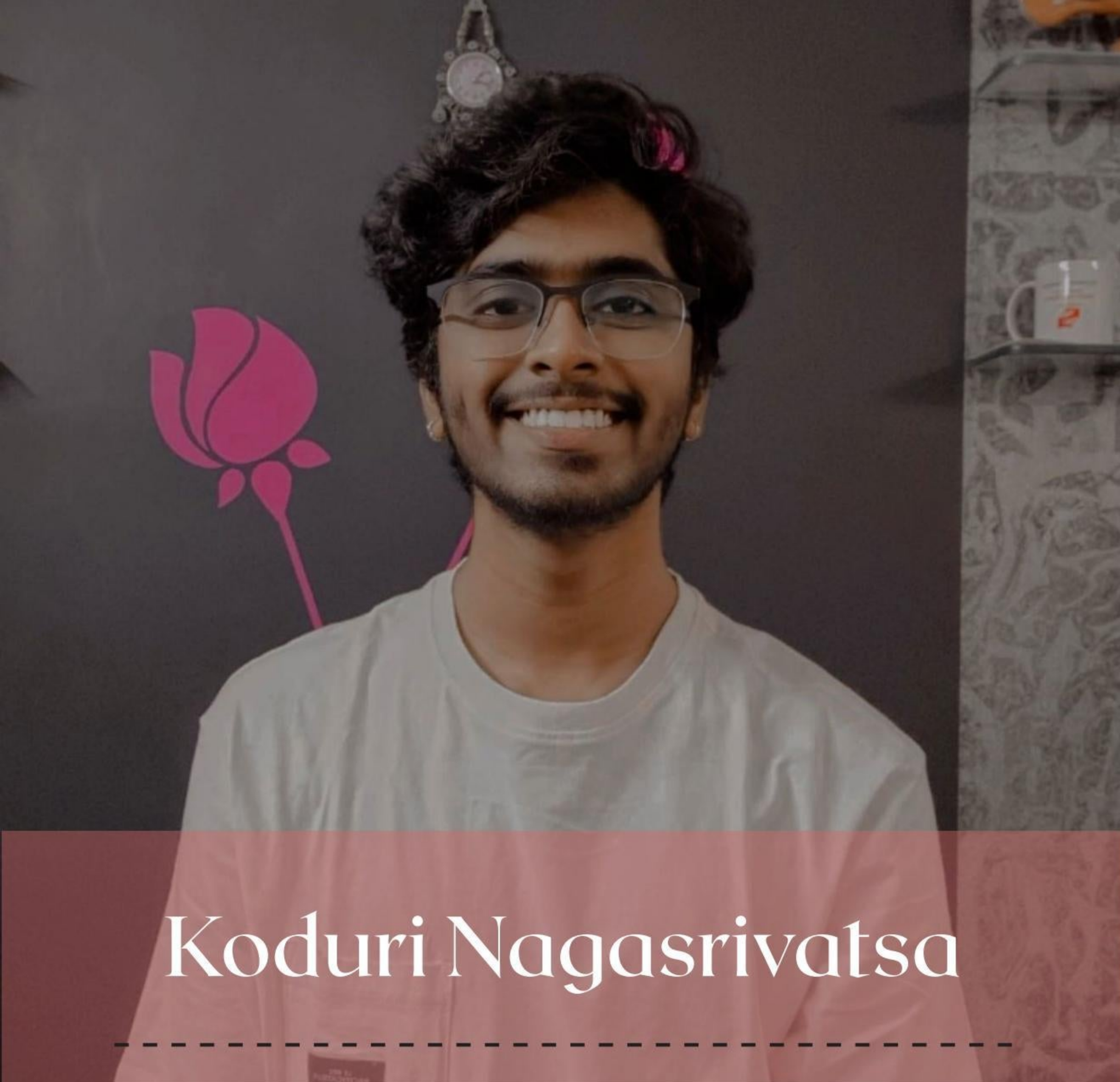

Koduri Nagasrivatsa

I am a student of R.V College of Architecture, pursuing 4th year of Architecture Undergraduate degree. Although I am a budding architect, I am more inclined toward the metaphysical aspects of Architecture. At RV, I introduced the idea of story telling in architecture, in my design. I am well versed with computer skills and have a good experience with sketching. Literature, different art forms and my love for travel, are indeed vital instruments in my architectural perceptions.

S/O: Koduri Sridevi

Date of Birth 26th December, 2000

Contact

+91 8978645888

srivatsakoduri@gmail.com

Address

1-9-285/9, Sridevi Nilayam, Ram Nagar Gundu, Vidya Nagar, Hyderabad - 500044
Telangana

Languages

English, Telugu, Hindi

Educational Qualification

- 2016  All Saints' High School, Hyderabad
- 2018  Little Flower Junior College, Hyderabad
- 2018 - Present  R.V. College of Architecture, Bangalore

Professional Skill Set

Building Information Modelling

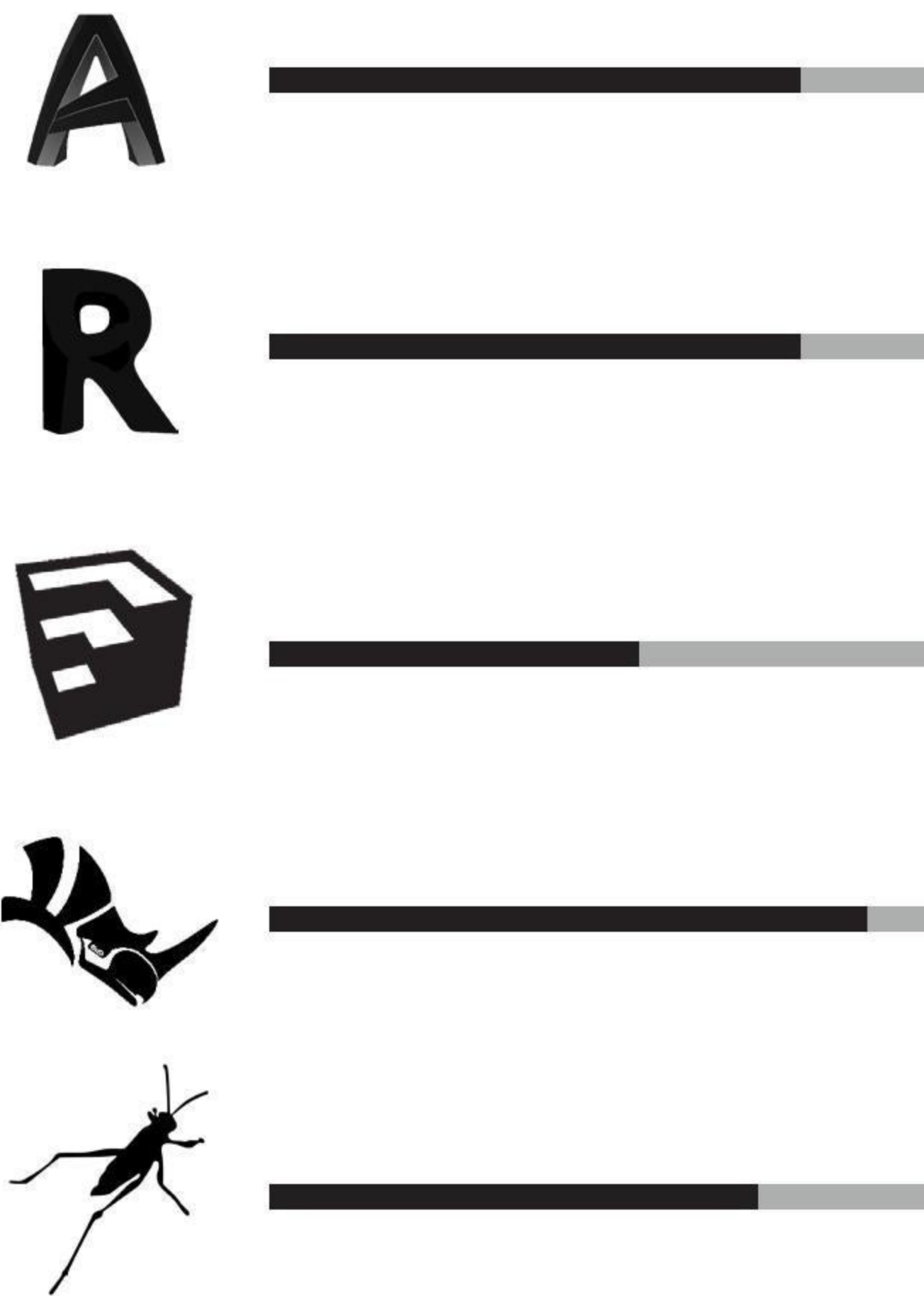

Visualization

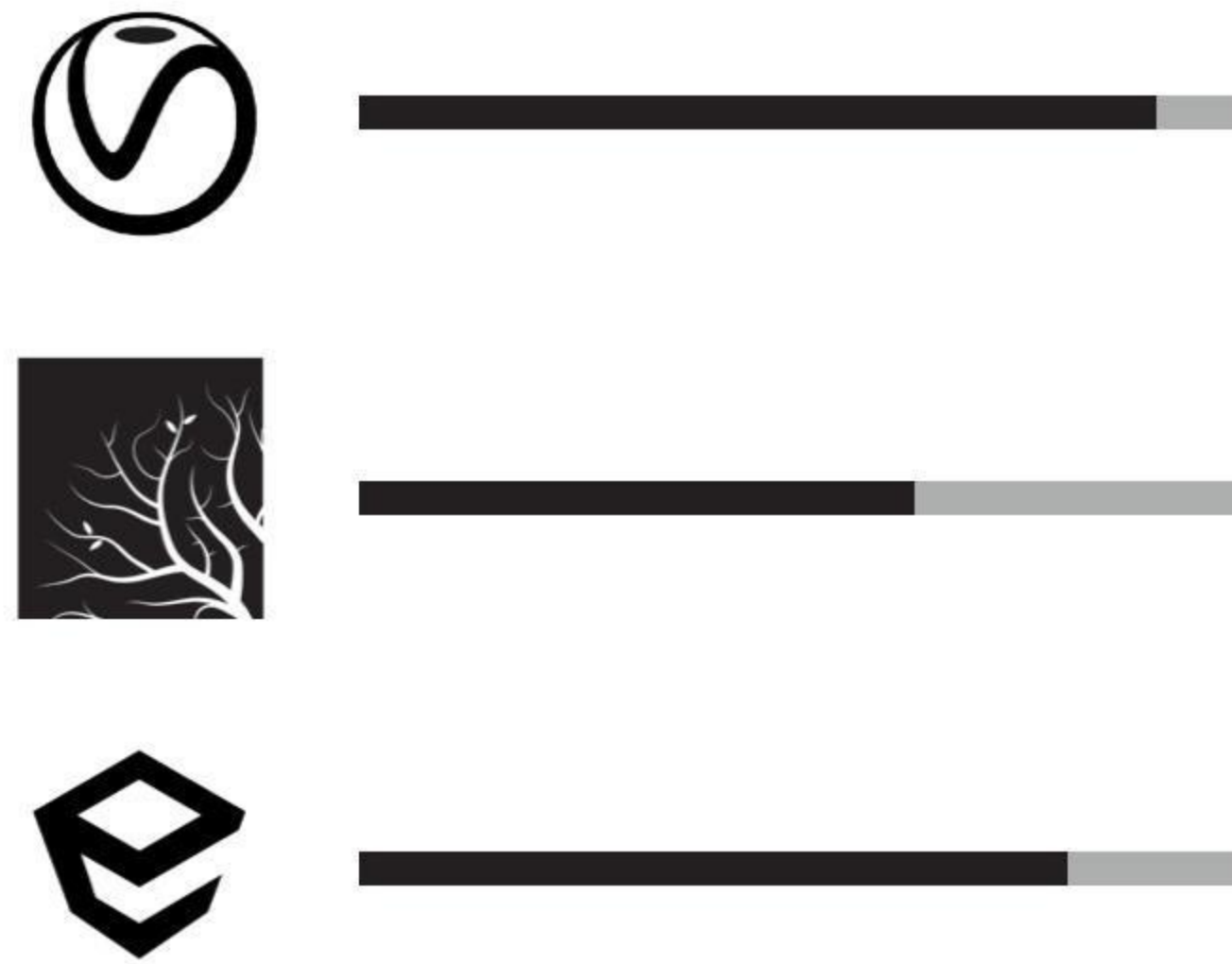

Adobe Softwares

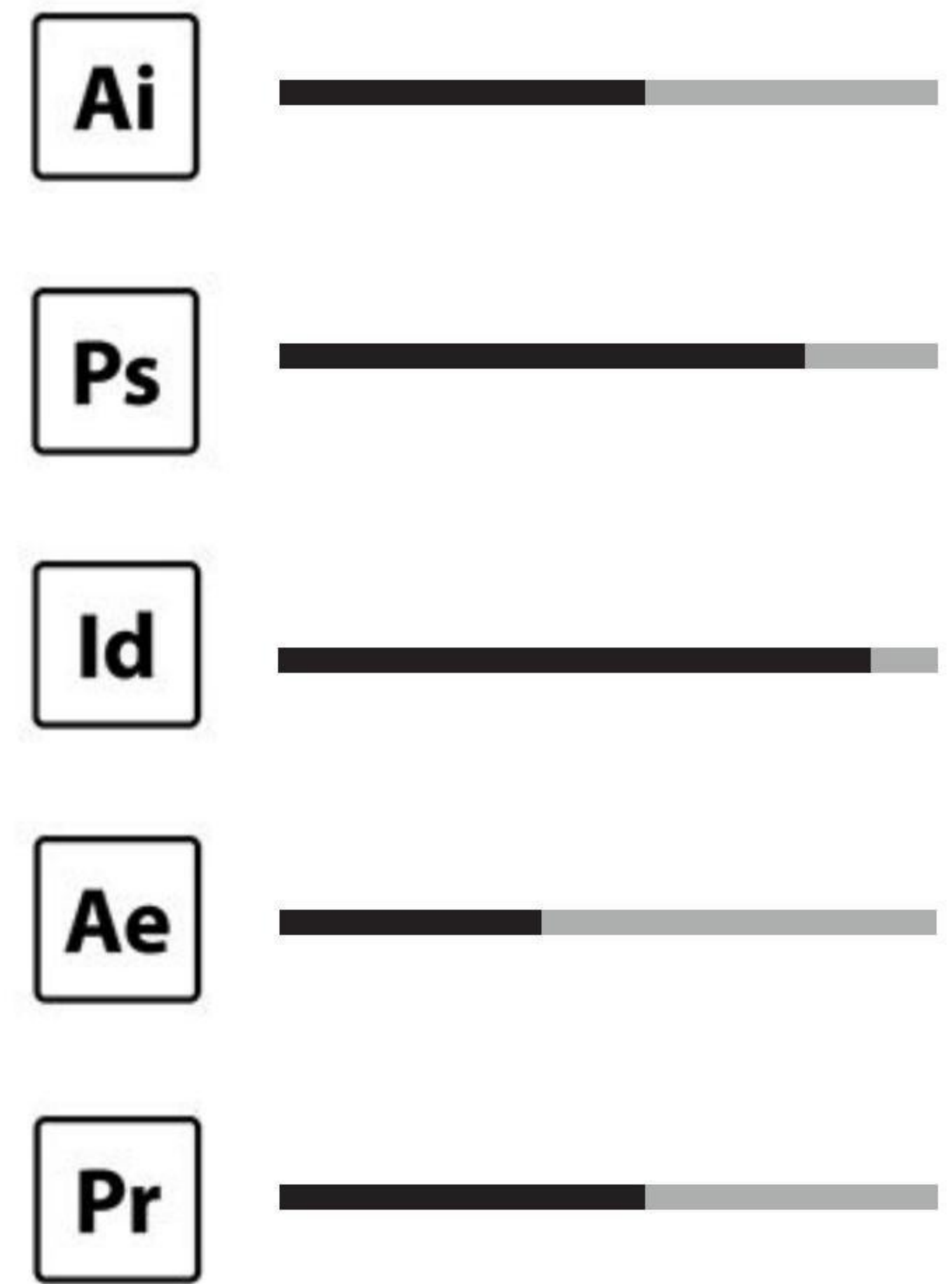

MS Office

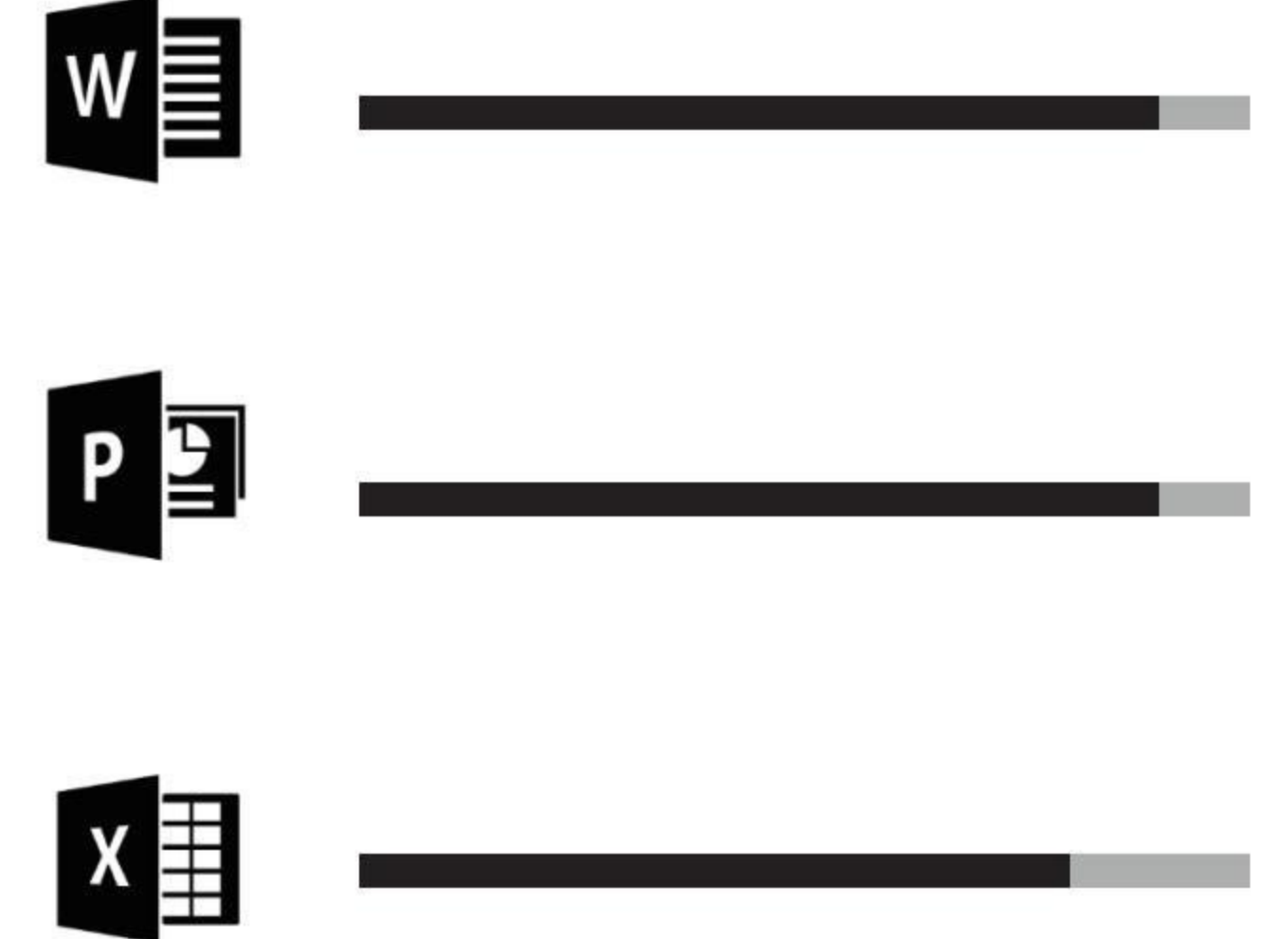

Additional Skill Set



Autodesk Sketchbook



Procreate



Krita

Competitions

2nd Prize	Navrachna Design Challenge 2020 "Love in the time of an Epidemic"
Winning Entry	DCDC Design Challenge – Design area of one's choice
Participation	DCDC Design Challenge – Product design
Participation	Sustainable Design Challenge by Aditya College of Architecture, Mumbai
Participation	Render Battle 2020 – The Charette
Participation	Archiol – Artuminate; Artdeco style
Participation	Archiol – Artuminate; Gothic style
Shortlistment	Archiol – Artuminate; Bauhaus style
Shortlistment	Archiol – Artuminate; Bohemian style
Participation	Archiol – Artuminate; Metaphysics in Architecture

file:///E:/Academics/Semester%208/Internship/New%20folder/Architectural%20Journalism_Srivatsa%20Koduri.htm

Miscellaneous Work

Elevation Design of an Office Project in Alwal, Hyderabad

Interior Design of an Office+ Residence Project in Alwal, Hyderabad

Assisted in developing Design Plans of an Office+ Residence Project in Alwal, Hyderabad

Logo Design for a Youtube Channel – Lahari's Kitchen

Video Editing for a Youtube Channel – Lahari's Kitchen

Workshops

Bamboo Workshop at R.V. College of Architecture

Hafale Wood Carpentry Workshop at R.V. College of Architecture

Urban sketching Workshop at R.V. College of Architecture

Leadership and participation

Head | Cultural committee R.V. College of Architecture, 2022

Class Representative | R.V. College of Architecture, 2018 to present

Member | Installation committee | R.V. College of Architecture, 2022

Member | Panels committee | R.V. College of Architecture, 2022

Member | Publicity committee | R.V. College of Architecture, 2022

Hobbies

Sketching

Singing

Reading

Poetry Writing

Travelling

table of

c

ntents

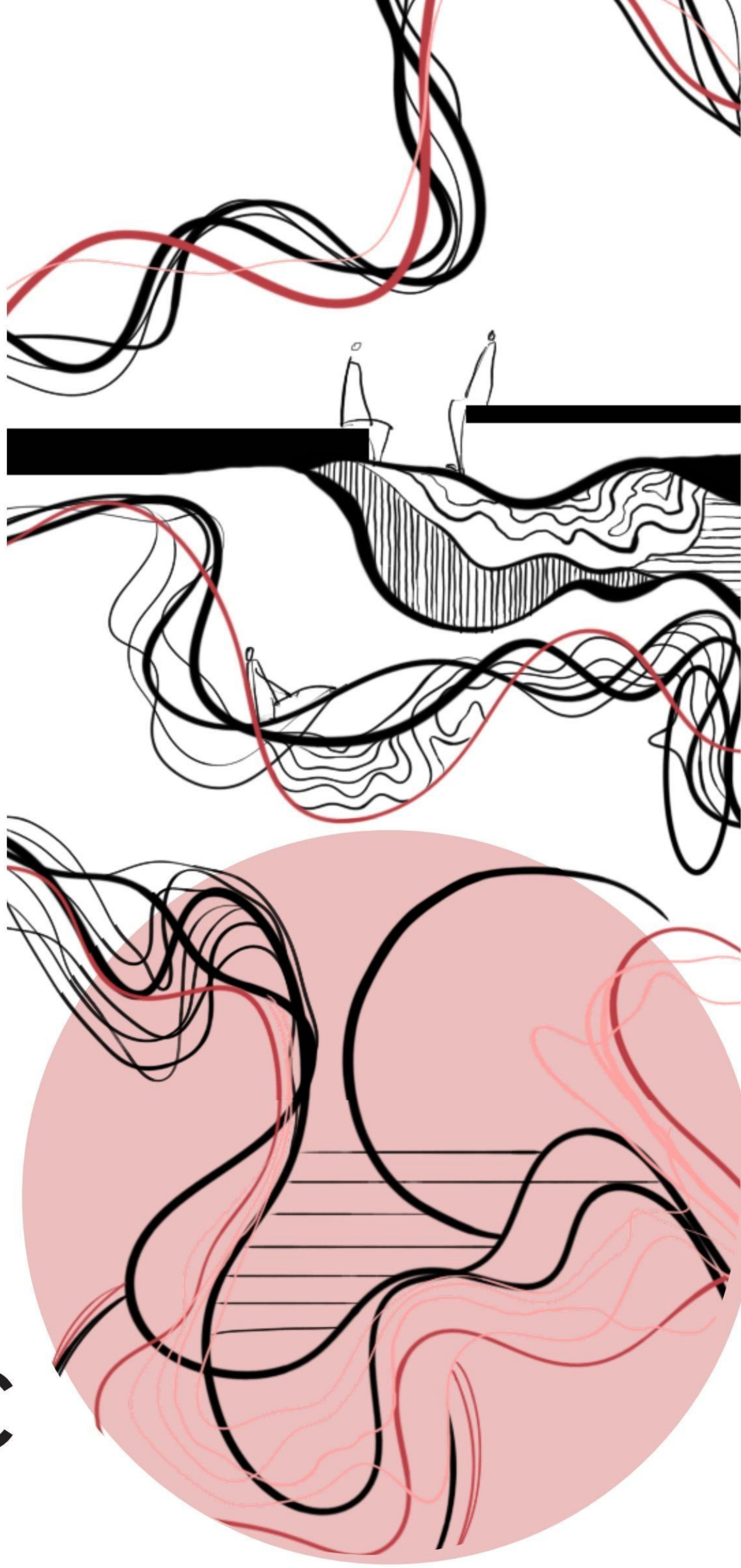

the navratnas

1

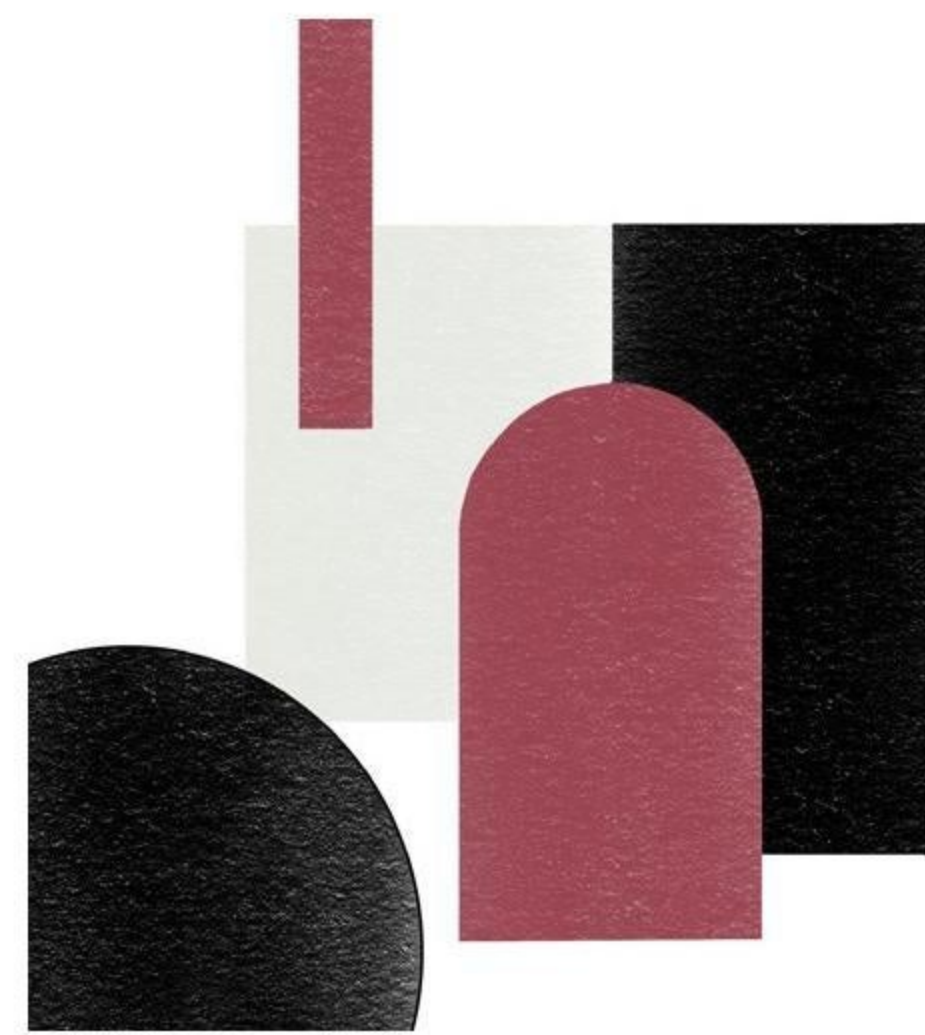

game of memories

2



ekatvam

3



(en)code

4



frolic rhythms

5

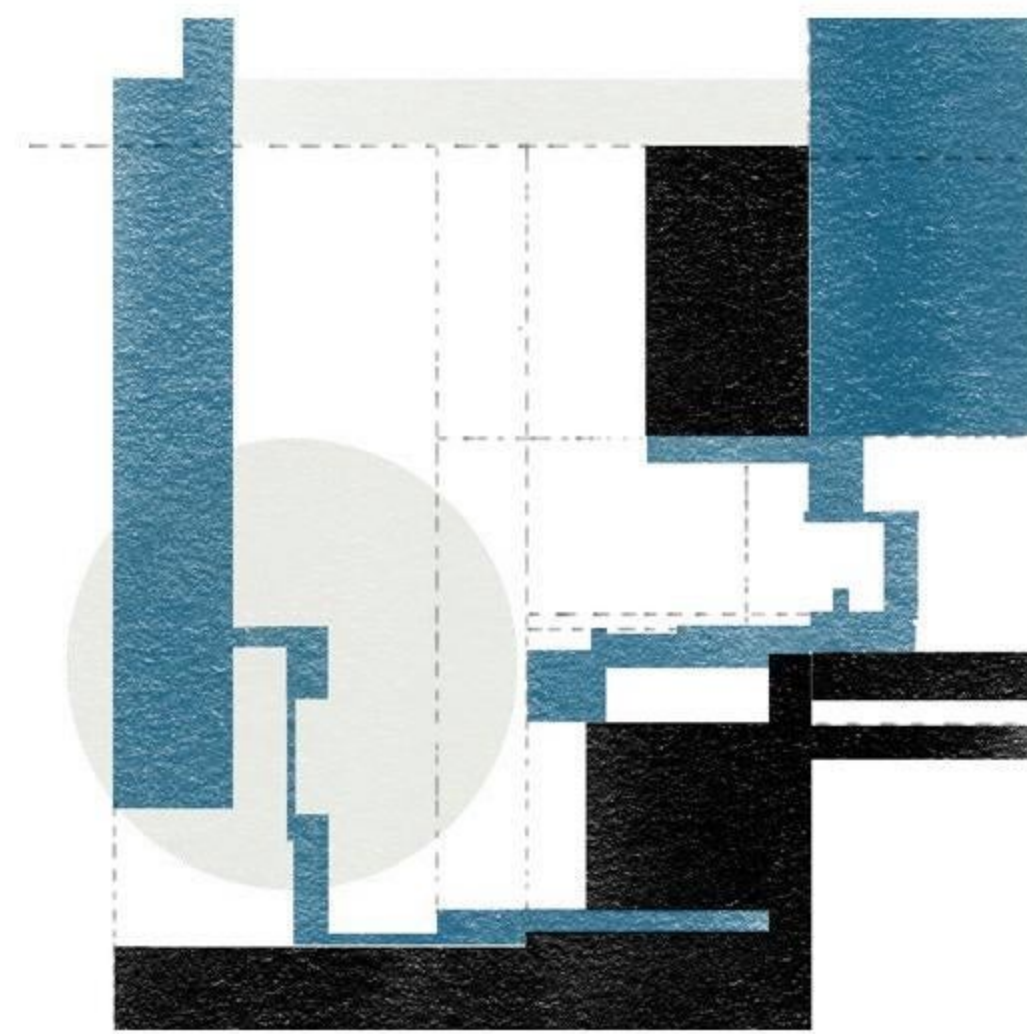

technical drawings

6



6 feet apart

7



exploring the 3rd dimension

8

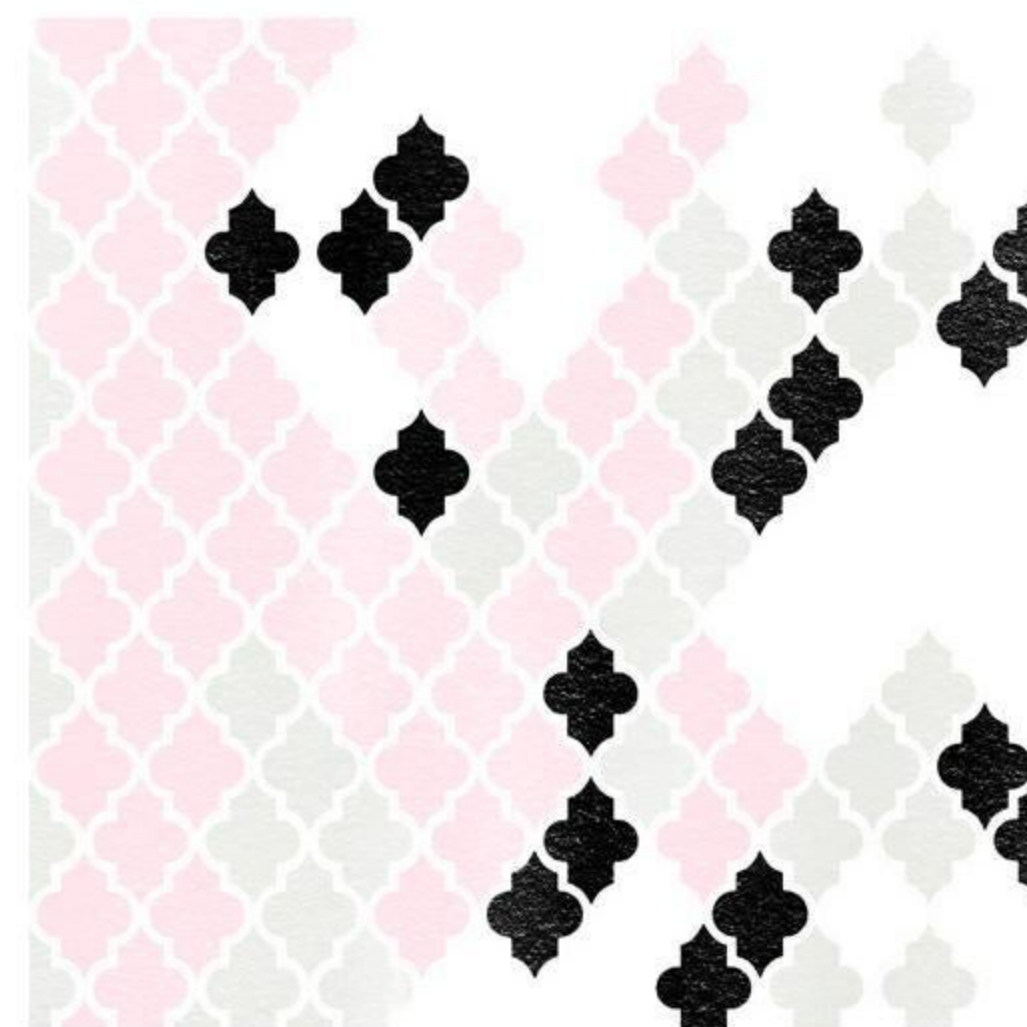

photographing memories

9



artworks



01

game of memories

Education plays an important role in the growth of a person as a character. The brief put forward for the studio was to relook at the idea of education concerning one's personal experience and city as a learning aid.

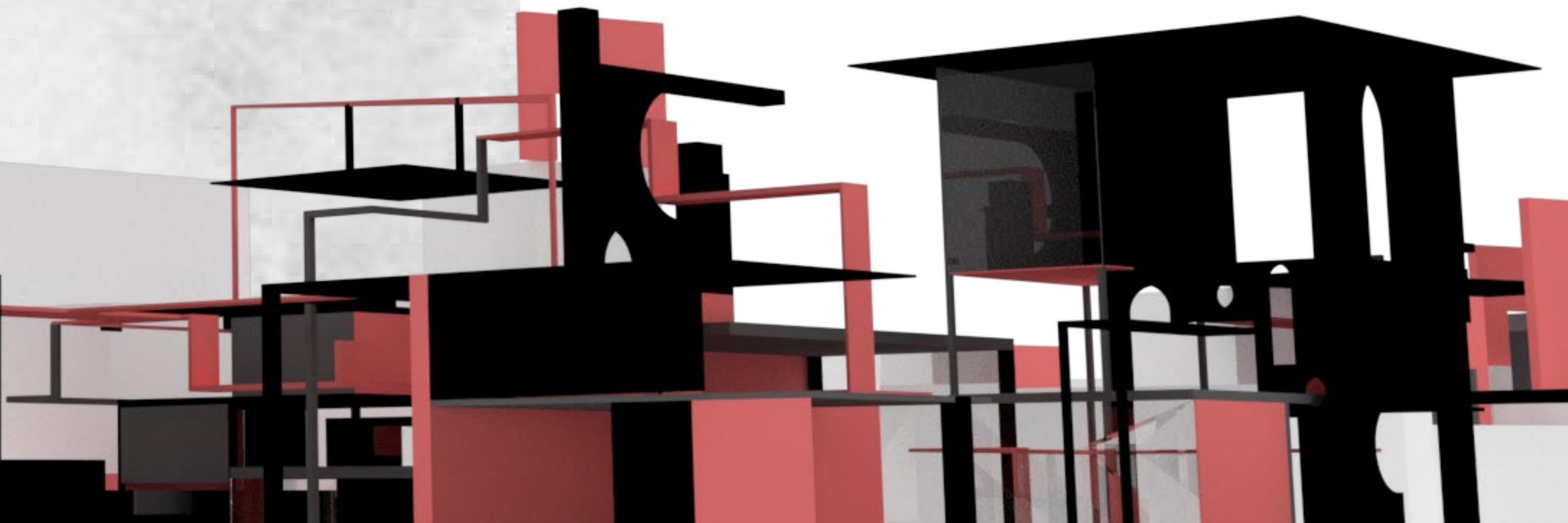





W[o]a]nderwalls set up the stage for its play - a game of memories. The protagonist of the play is the walls situated on this blank canvas. The dynamics of the play are choreographed by the existence of dynamic walls [walls that pivot and slide] and static walls. The walls recite the untold stories of the vicinity and give an insight into the main campus.

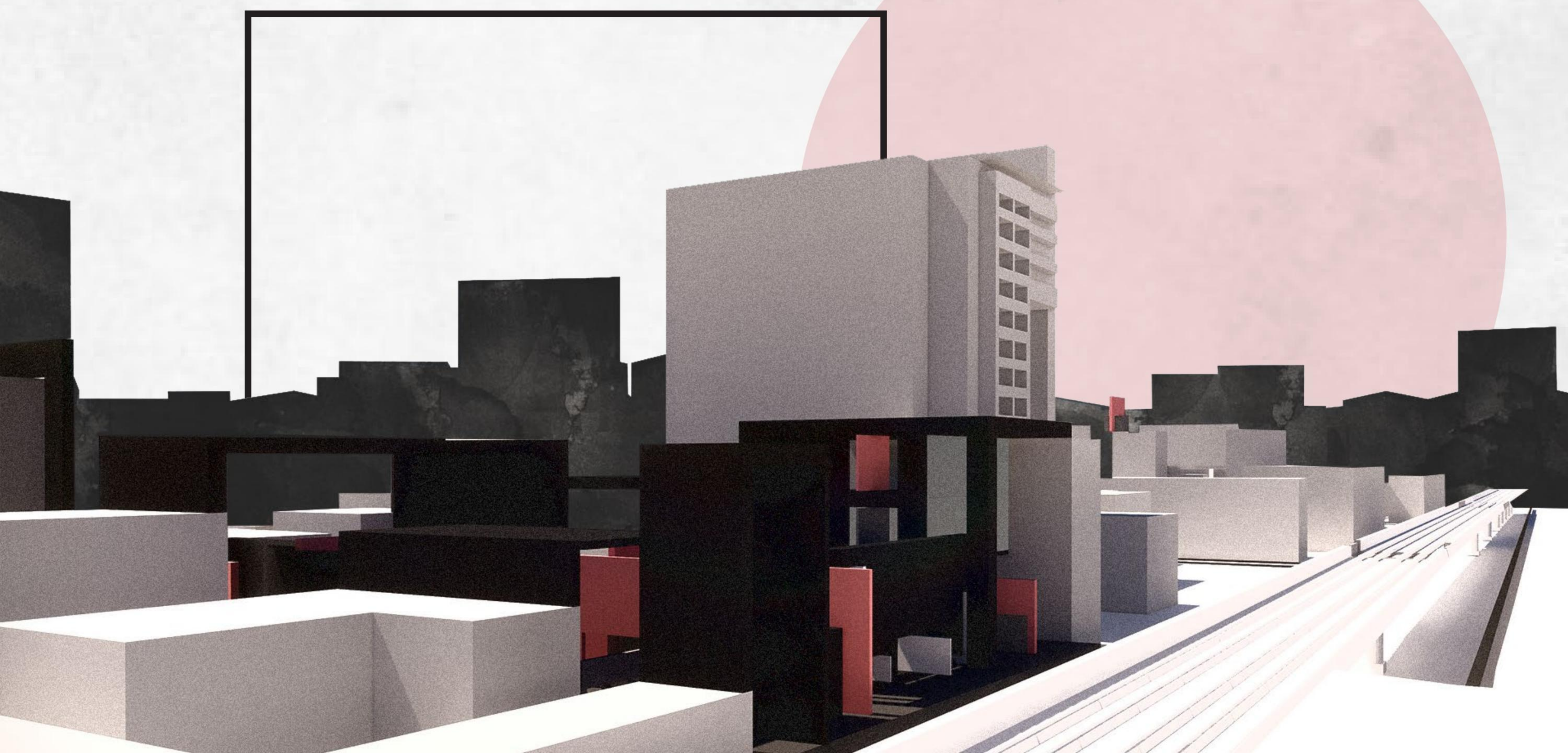

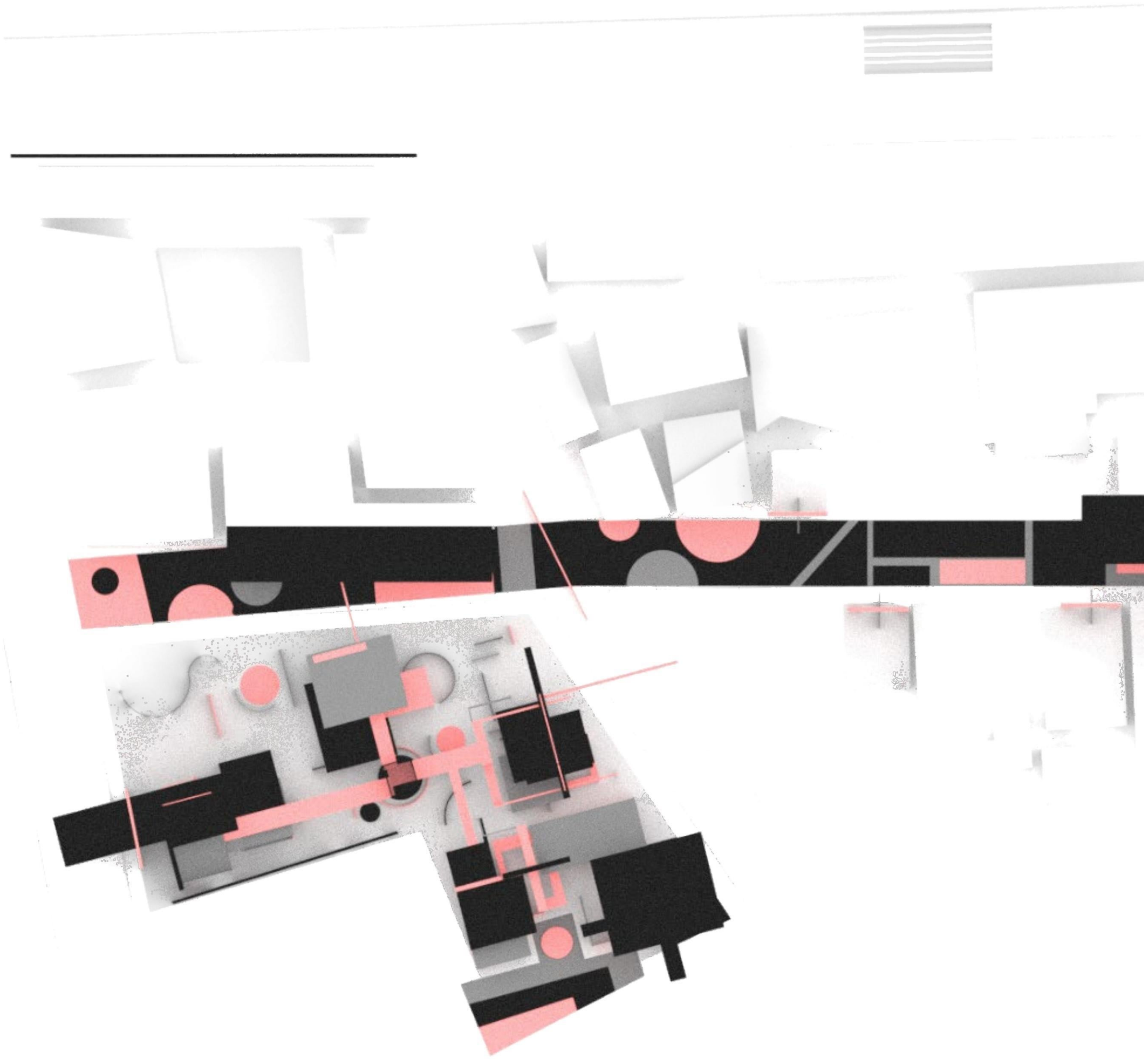

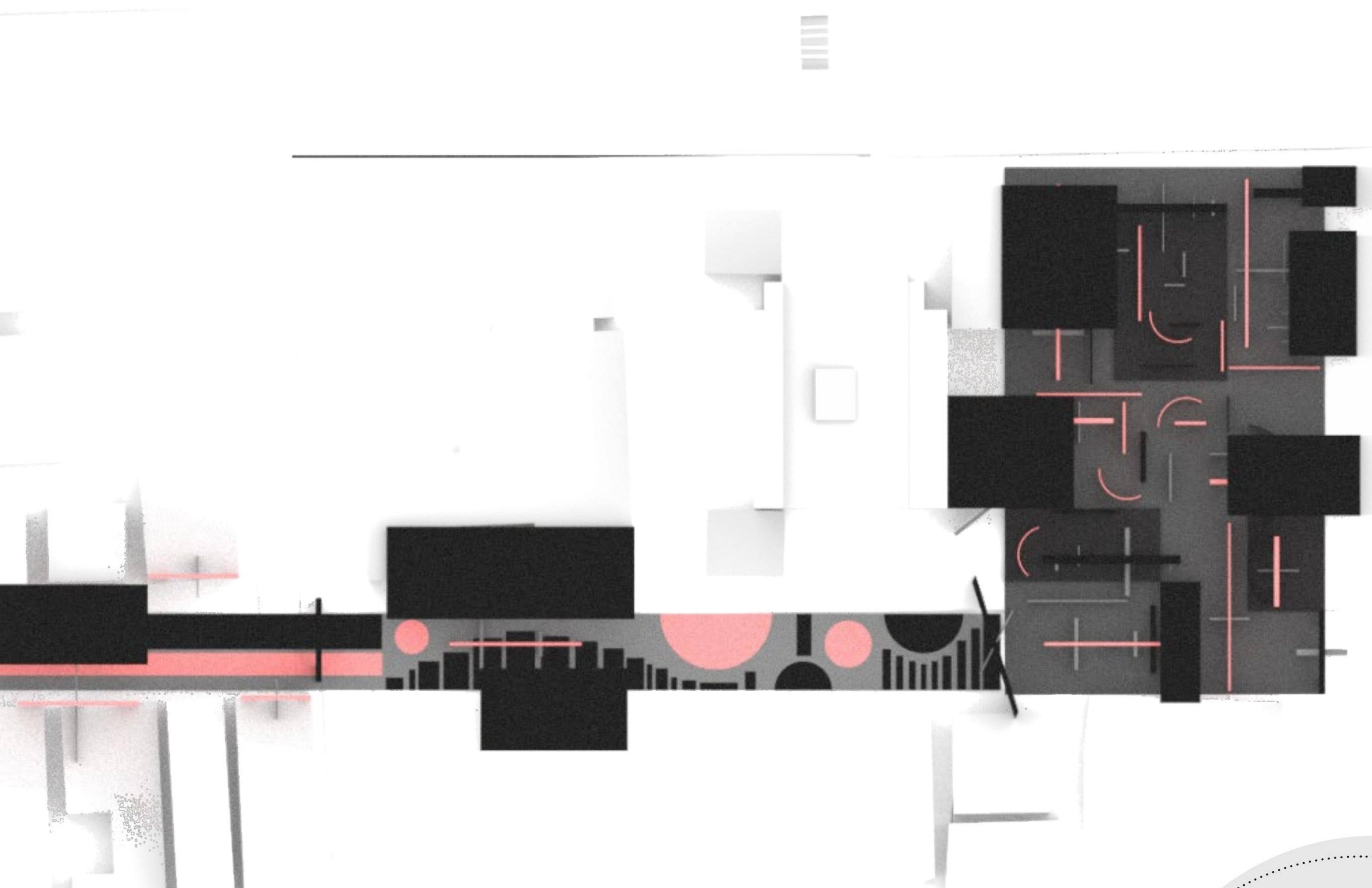

walking down the memory lane

Protruding elements and pivots attach itself to the buildings and the road like a parasite and act as road dividers or a barricade functionally yet caters to the transition of the language. The overheard panels can be used as signage for the shops.



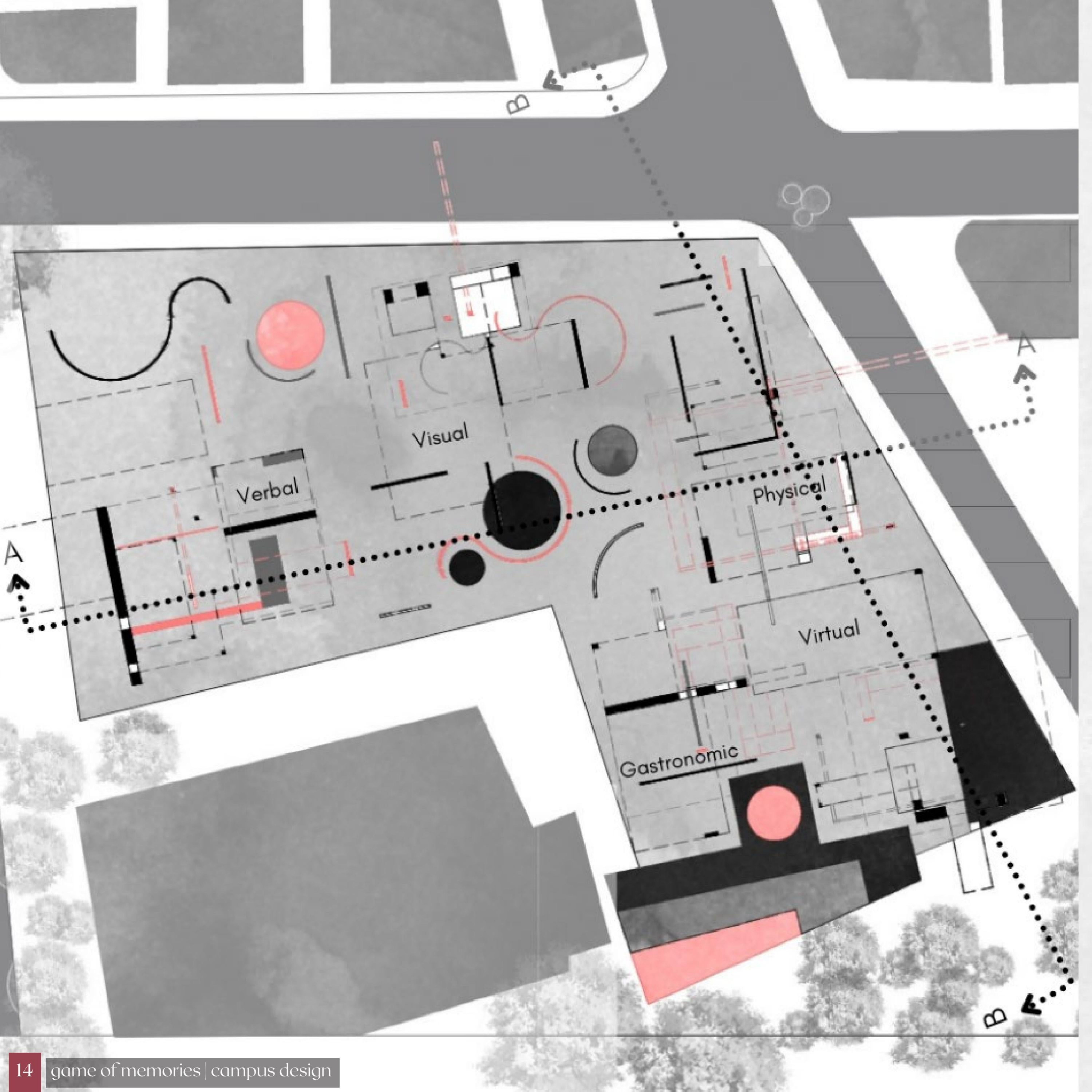

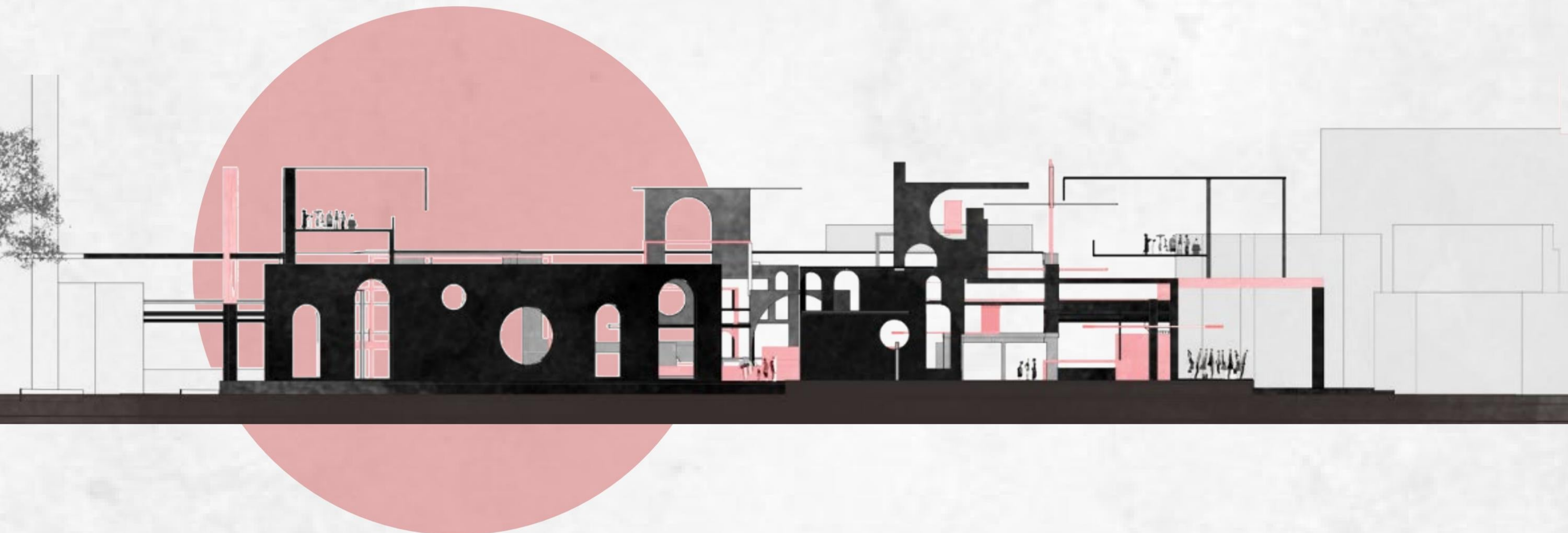

House of Cards

The black anchors become the stakeholders of the site and hence alter the ground plane. Slender pillars and columns rise these ground planes to a particular height and hence the system of walls moving continues on different levels.

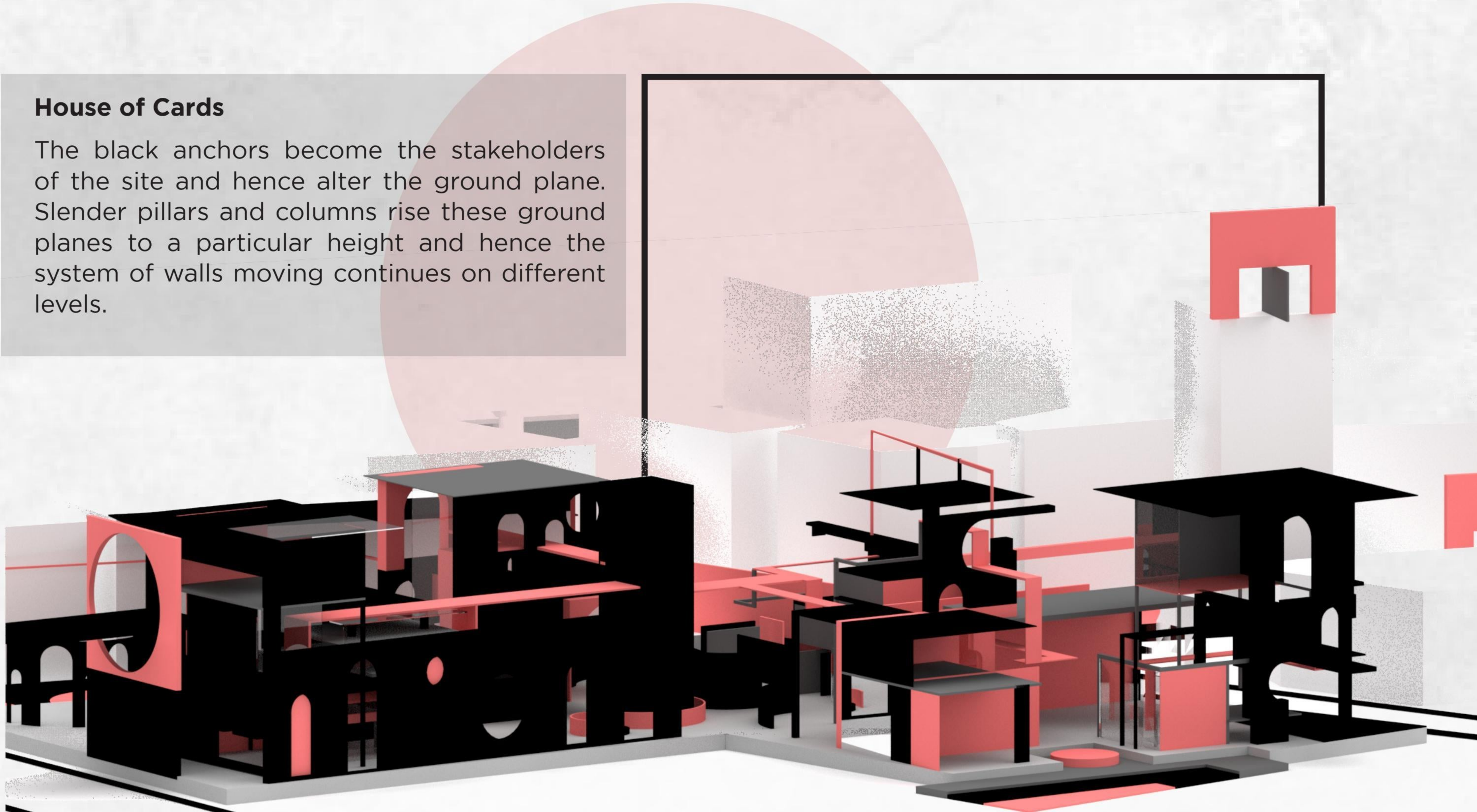



02

ekatvam

a moment in the present...

In the context of Chikkajala fort - the abandoned and forgotten monument, the breaking of the fort wall opened up its wings to the public realm and welcomed possibilities of being a host for community activities. The then introverted space transformed itself into an extrovert. With this possibility, the main task is to not make it Old v/s New and more Old and New.

Ekatvam is an attempt to connect the dots between the then existing glory and the current design intervention.



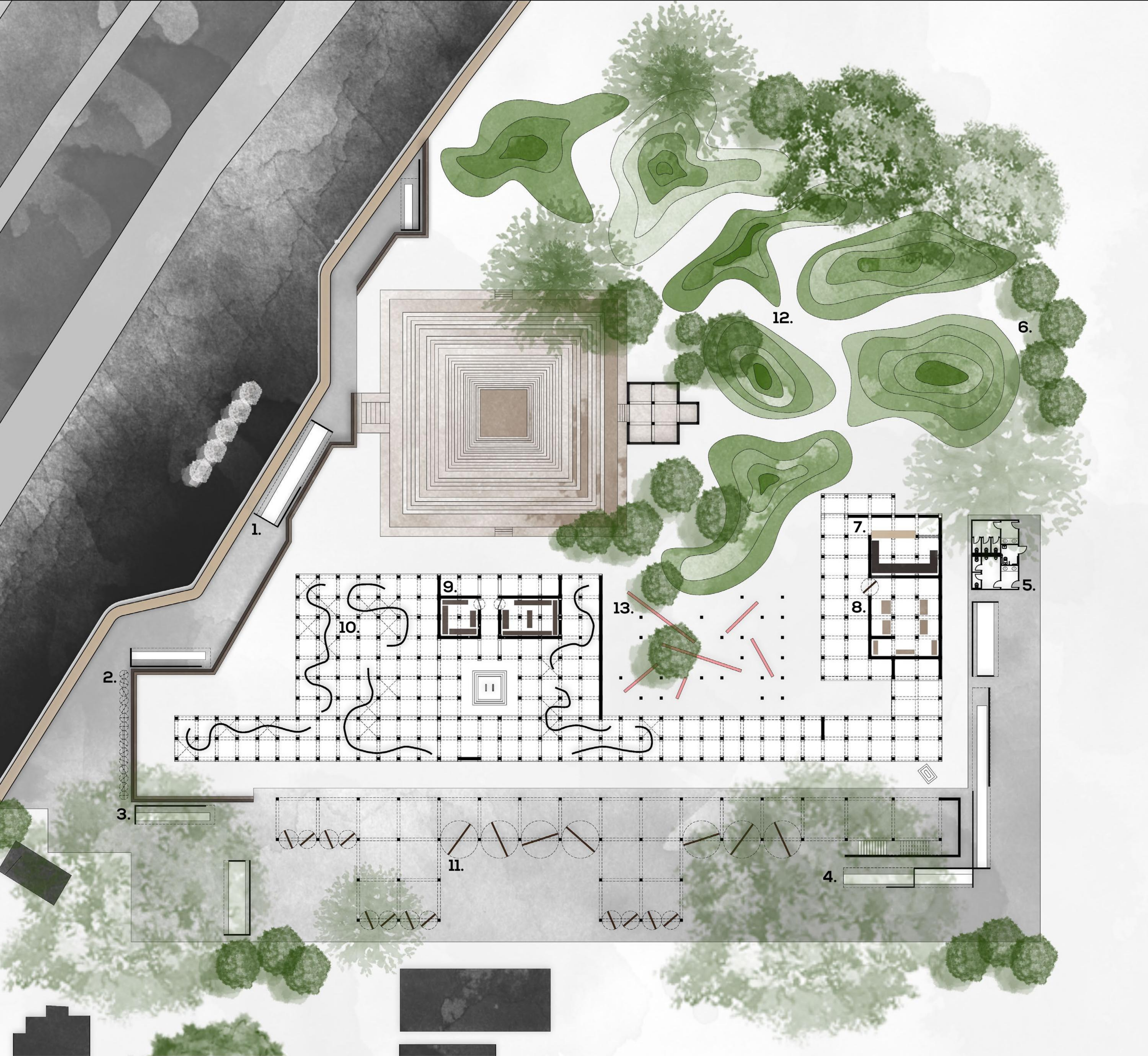



The built consists of berms adapting to the natural topography acting as performance spaces and seating spaces, library pockets/ niches of learning through the colonnade. The fort wall is replaced by seating spaces and mela spaces in the back and a bus stop in the front. A staircase beside the colonnade leads to the cultural training centre and anganwadis in the first level.



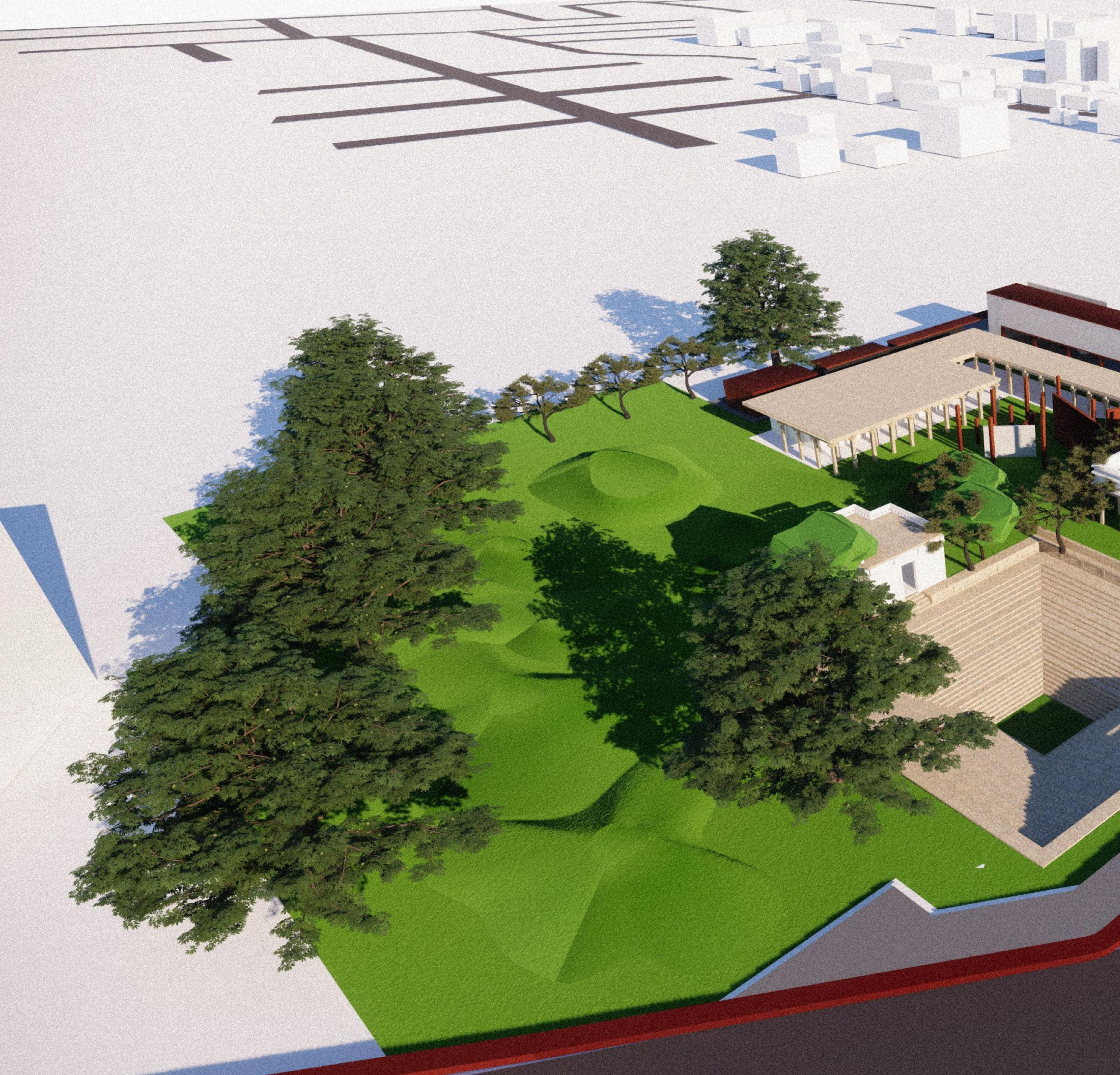







03

(en)code

In times like ours, when businesses are being re-invented, manufacturing as a process has undergone a lot of changes related to the process of making and the manner of selling. Small scale businesses and manufacturing entities which involve craftsmen are important players of this ecosystem and this studio set about looking at a premise to look at various ways of making a place for 'making'.



Unloading Driveway

Bus Stop Driveway

9M Wide Road

Skalvi International School

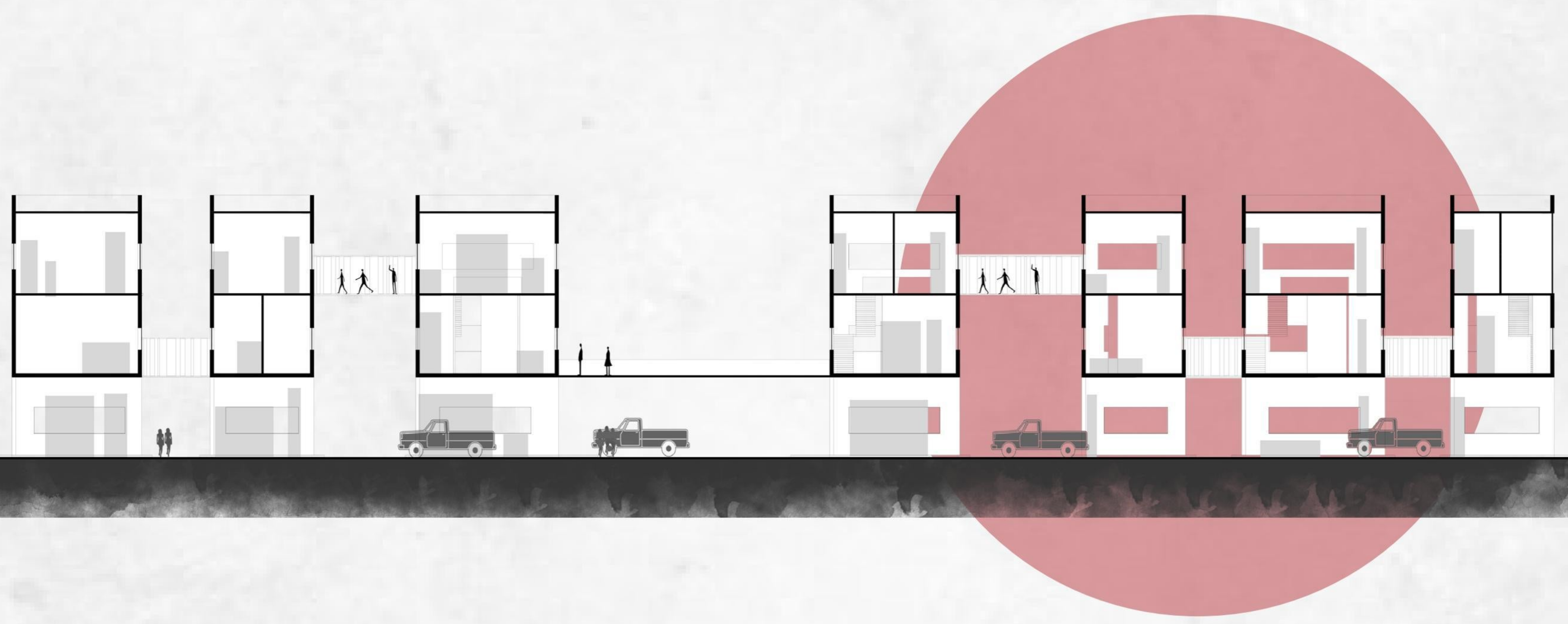

Section I
Scale - 1

The idea of the project was to retain the individuality of the manufacturing units after being set together as a group creating one identity for all the units. The 'Bar-Code' has been used as a concept to reflect the above where the bar code is an identity and the individual bars represent the individuality of units. Henceforth the seven vertical bars for the respective units stay put to the absoluteness of the project.

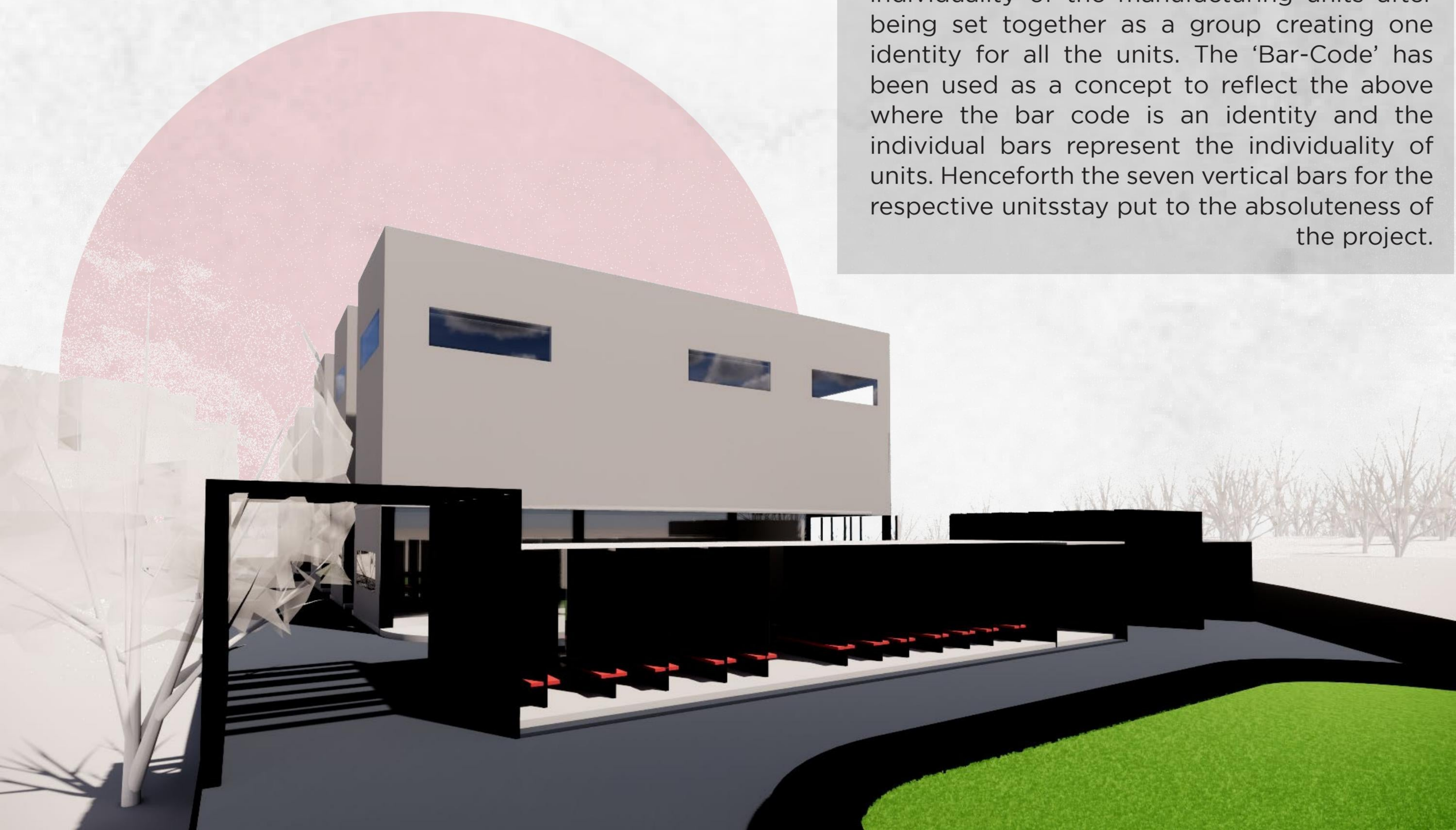

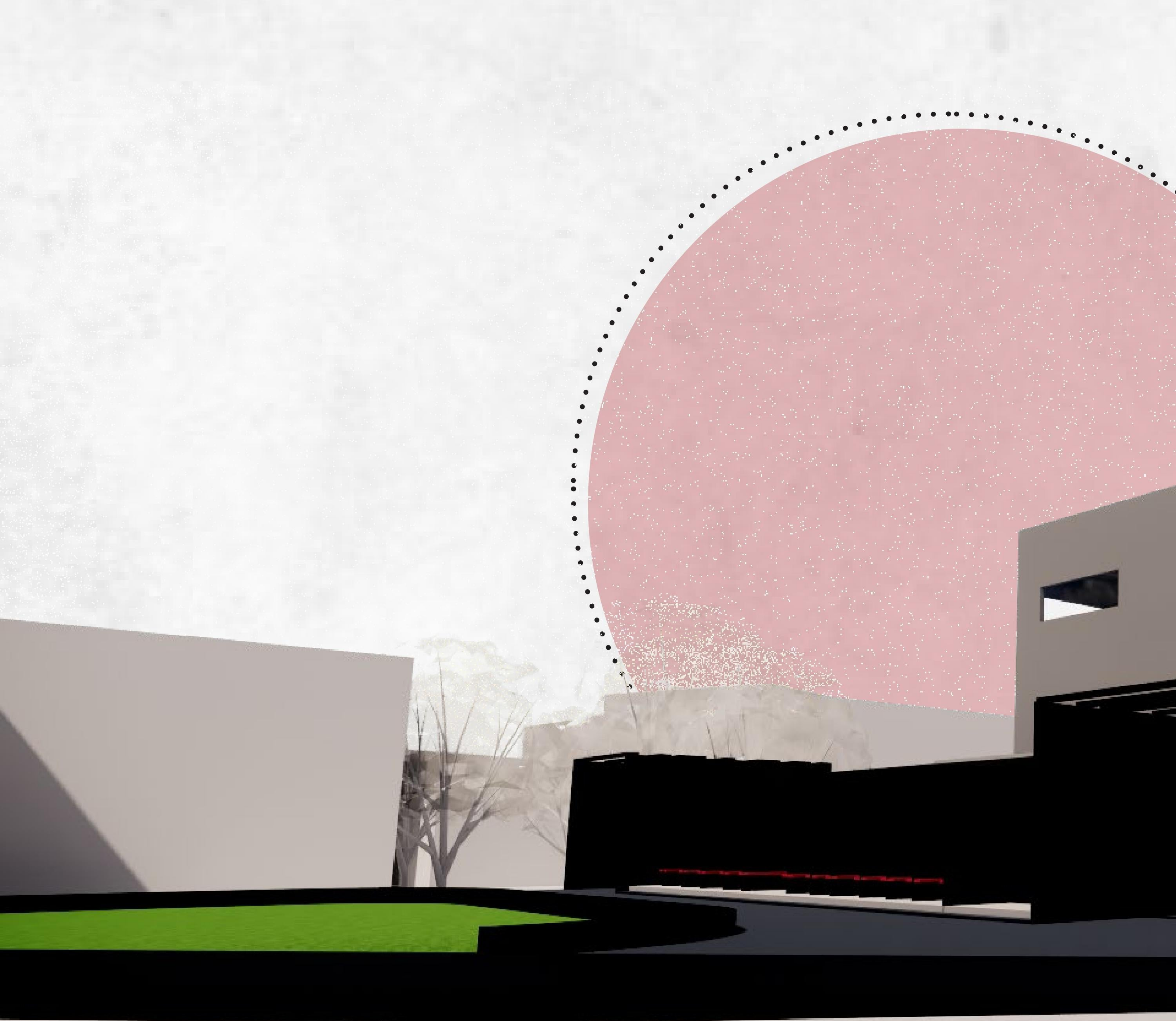

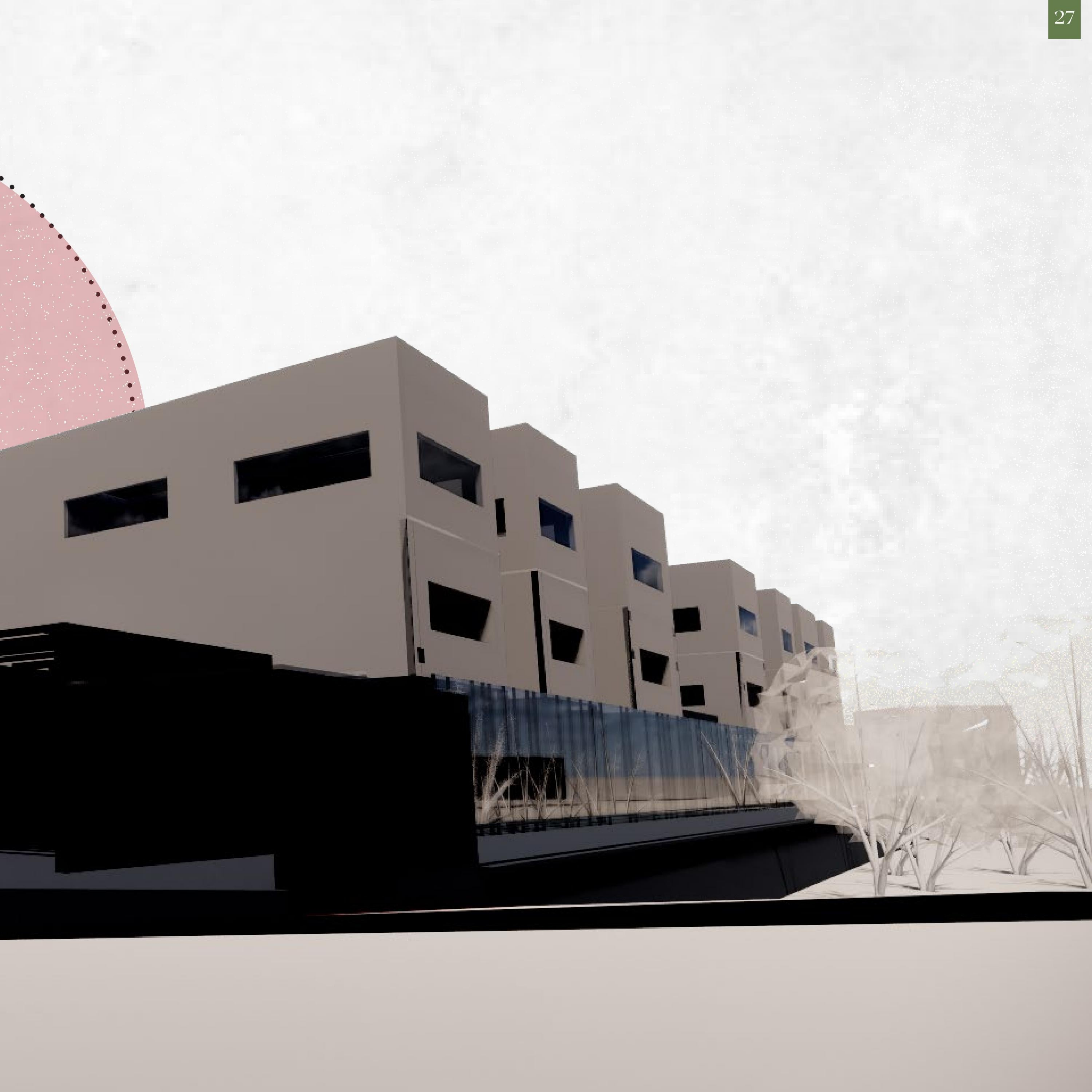

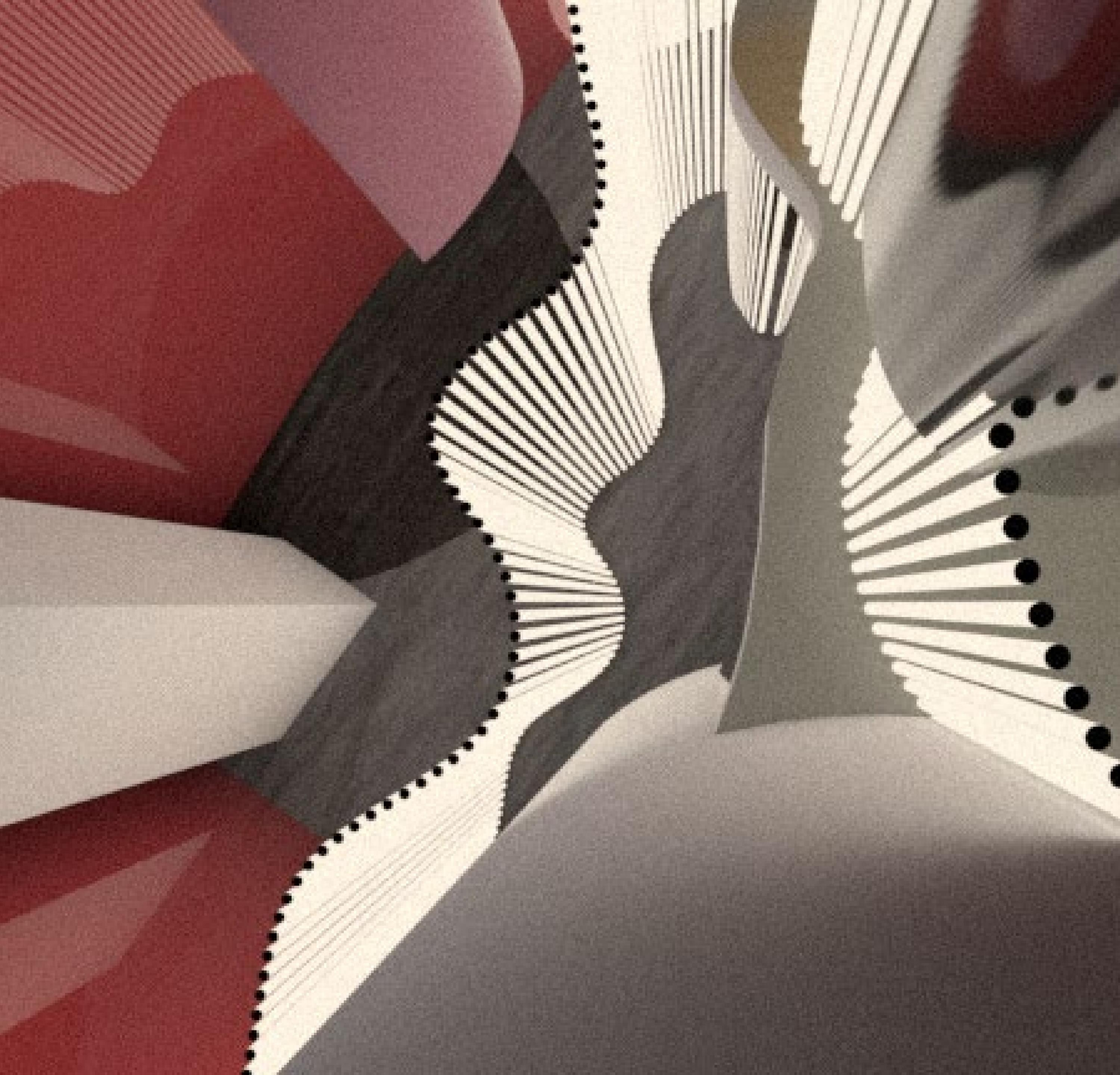

04

frolic rhythms

"Can we communicate truth using things that are false?"

- Es Devlin

Es Devlin is coming to Bangalore, India for an art residency program sponsored by Netflix. The artist/designer is here to work on the Art in Transit project. She is to inhabit a live-work space for a period of two years as part of a residency program. That also involves her participation with the community thereby exploring the liminal edge between inside and outside.

dramatics of spaces...



Entry Portal opens to the studio space
Studio Space with space as dramatic as
a cave with stalagmites and stalactites.
These intersections create pockets of
spaces used for display and recreational
activities.





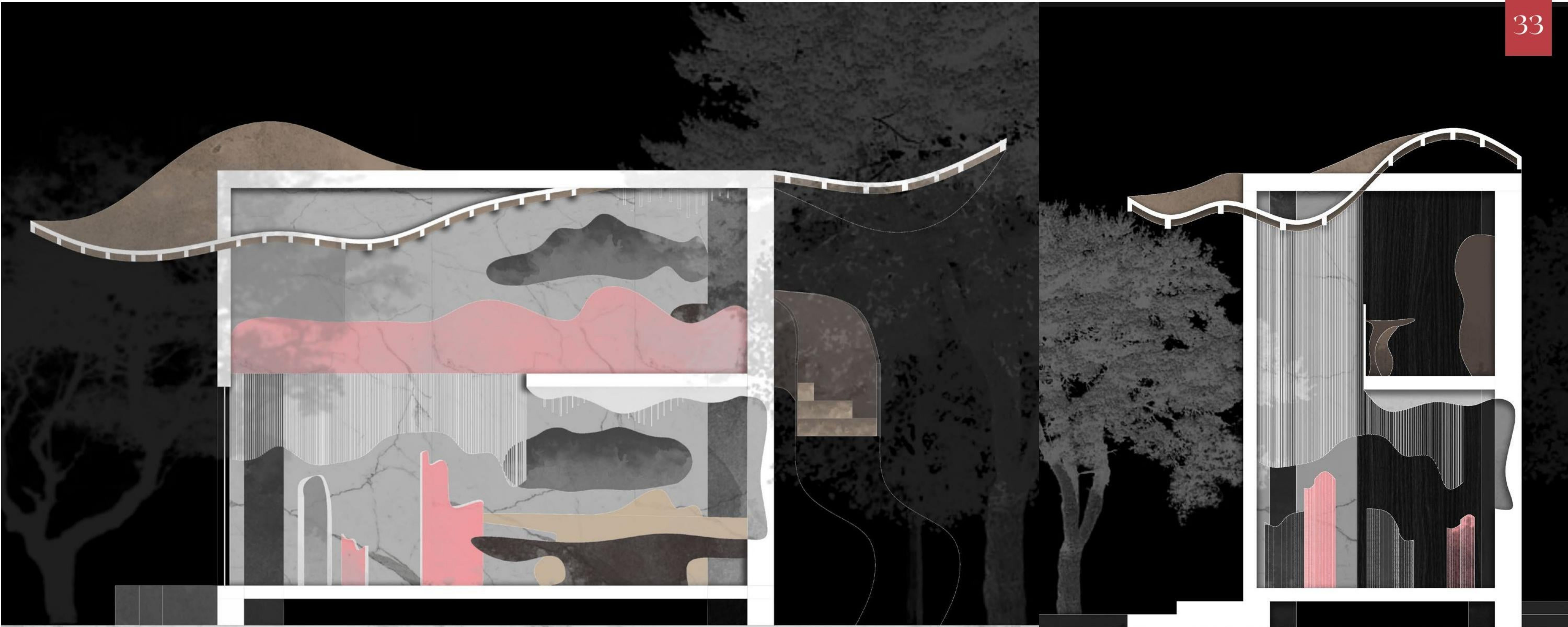

The language of the entry is continued into the interiors. Slivers stretch themselves into the space and break out of them opening up to the garden area. Stalactites' and Stalagmites'



06

technical drawings

The following technical drawings have been done for a retail+office project under working drawings and building construction tutoring.

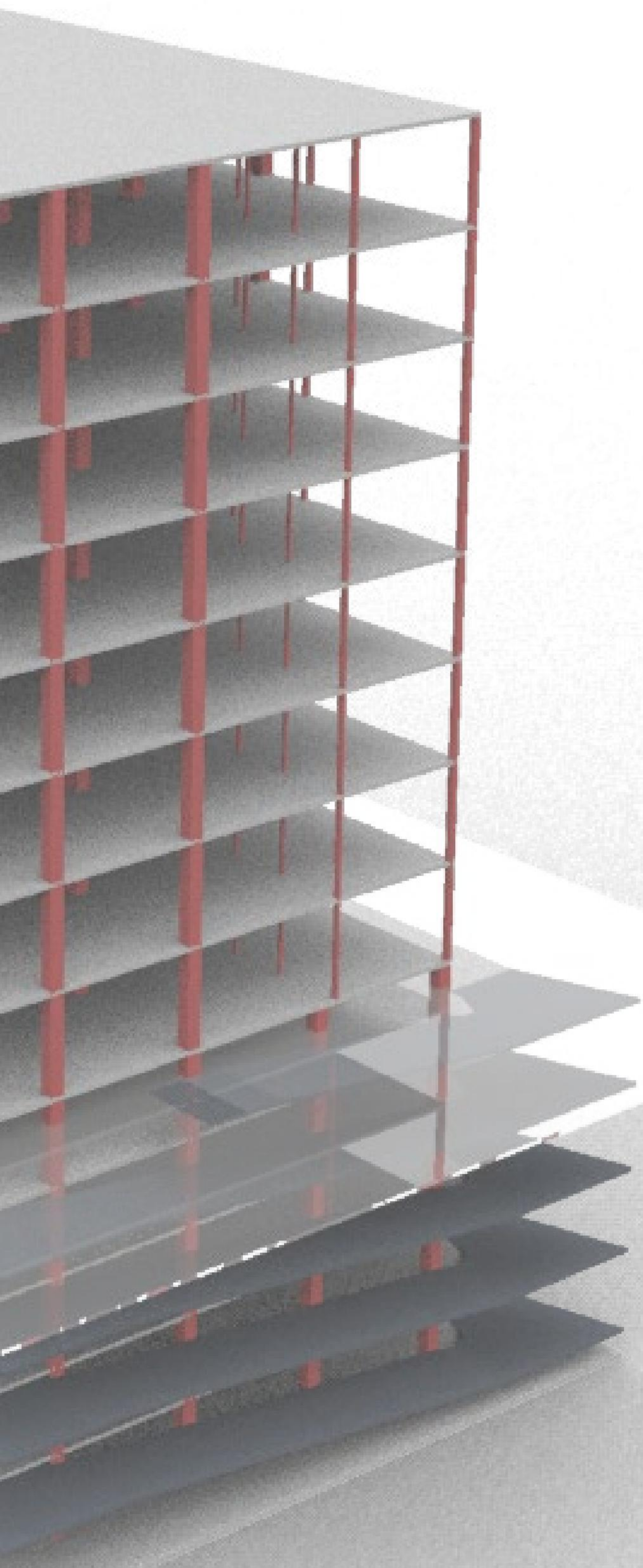
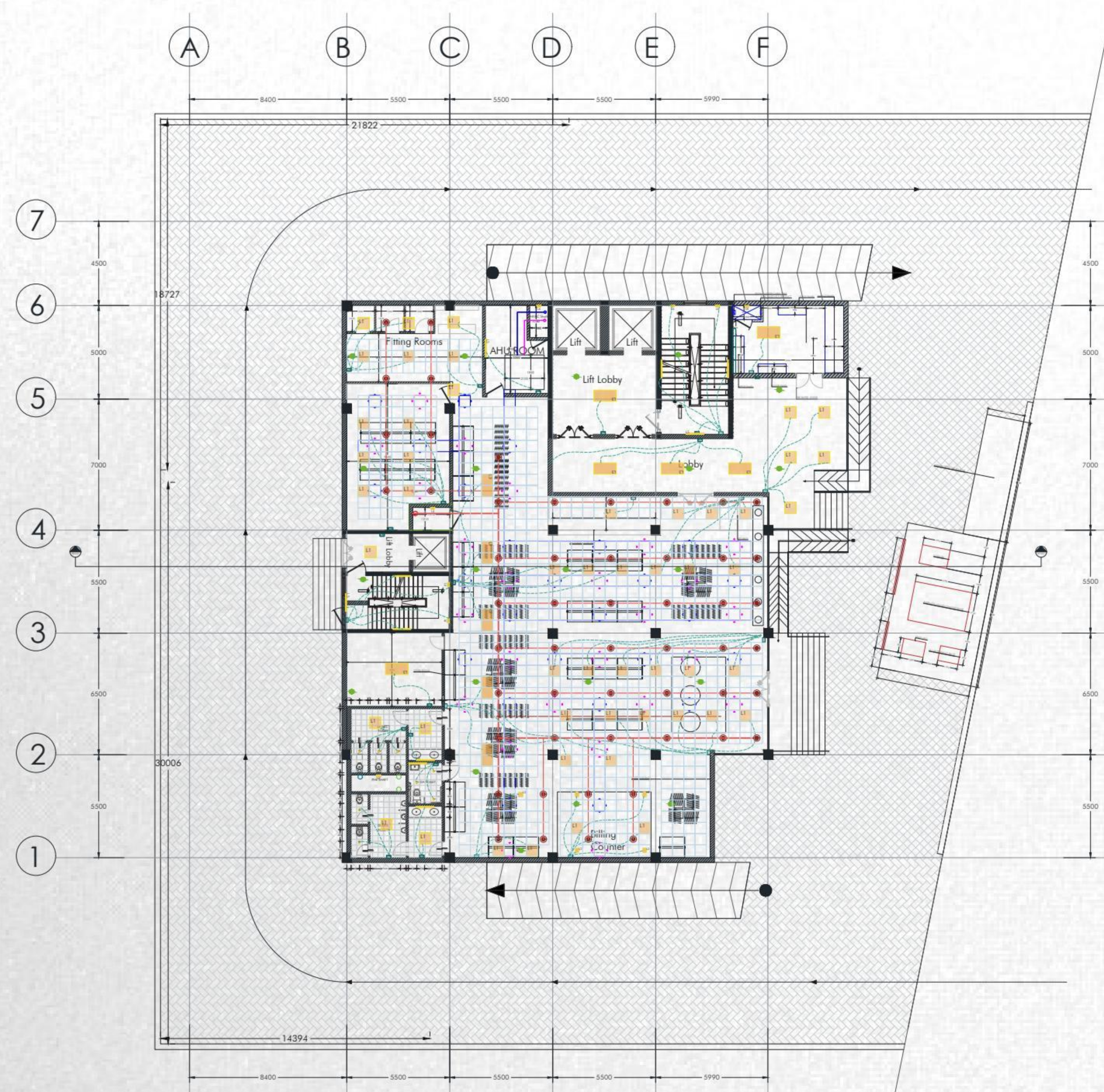

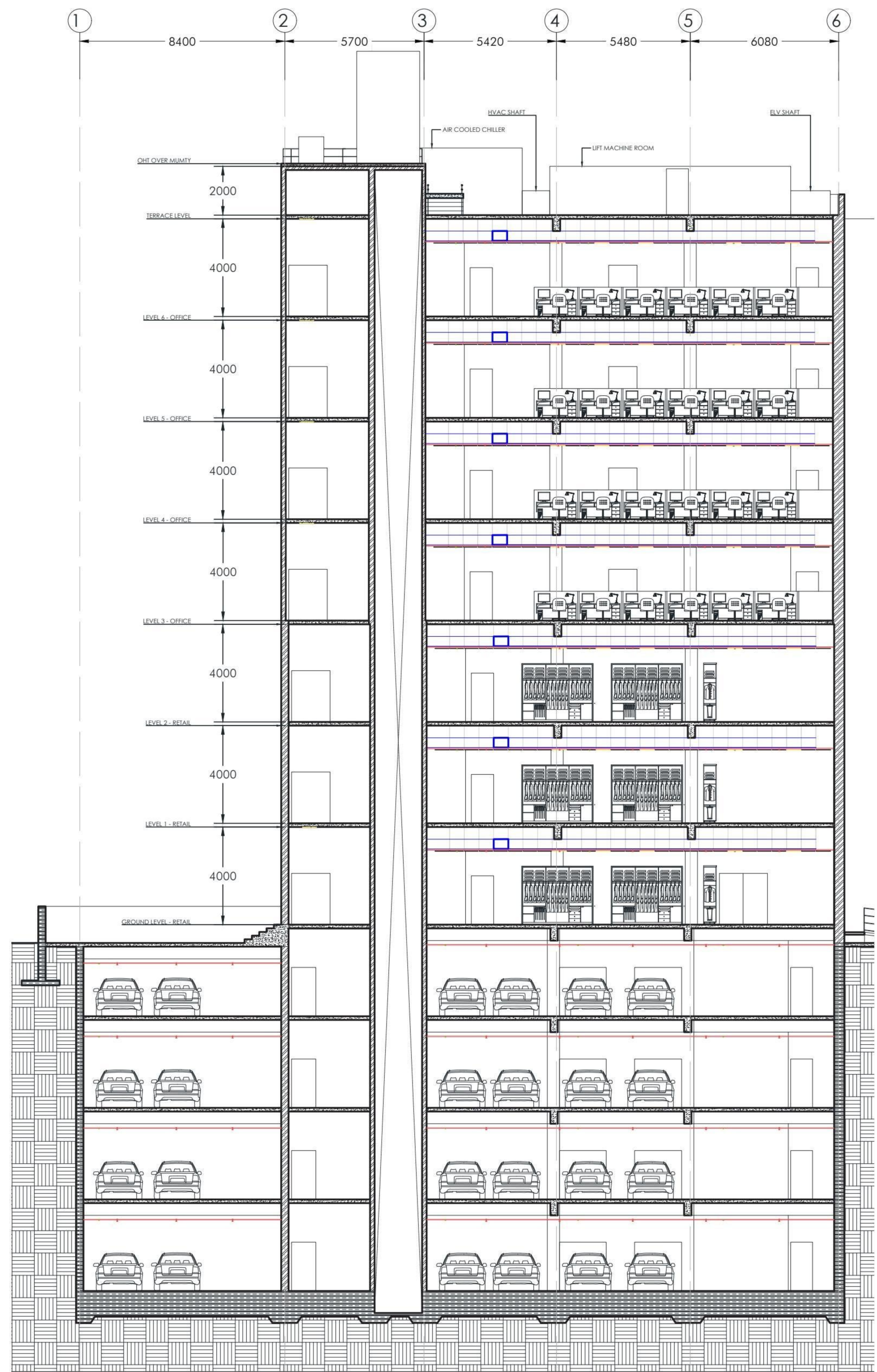
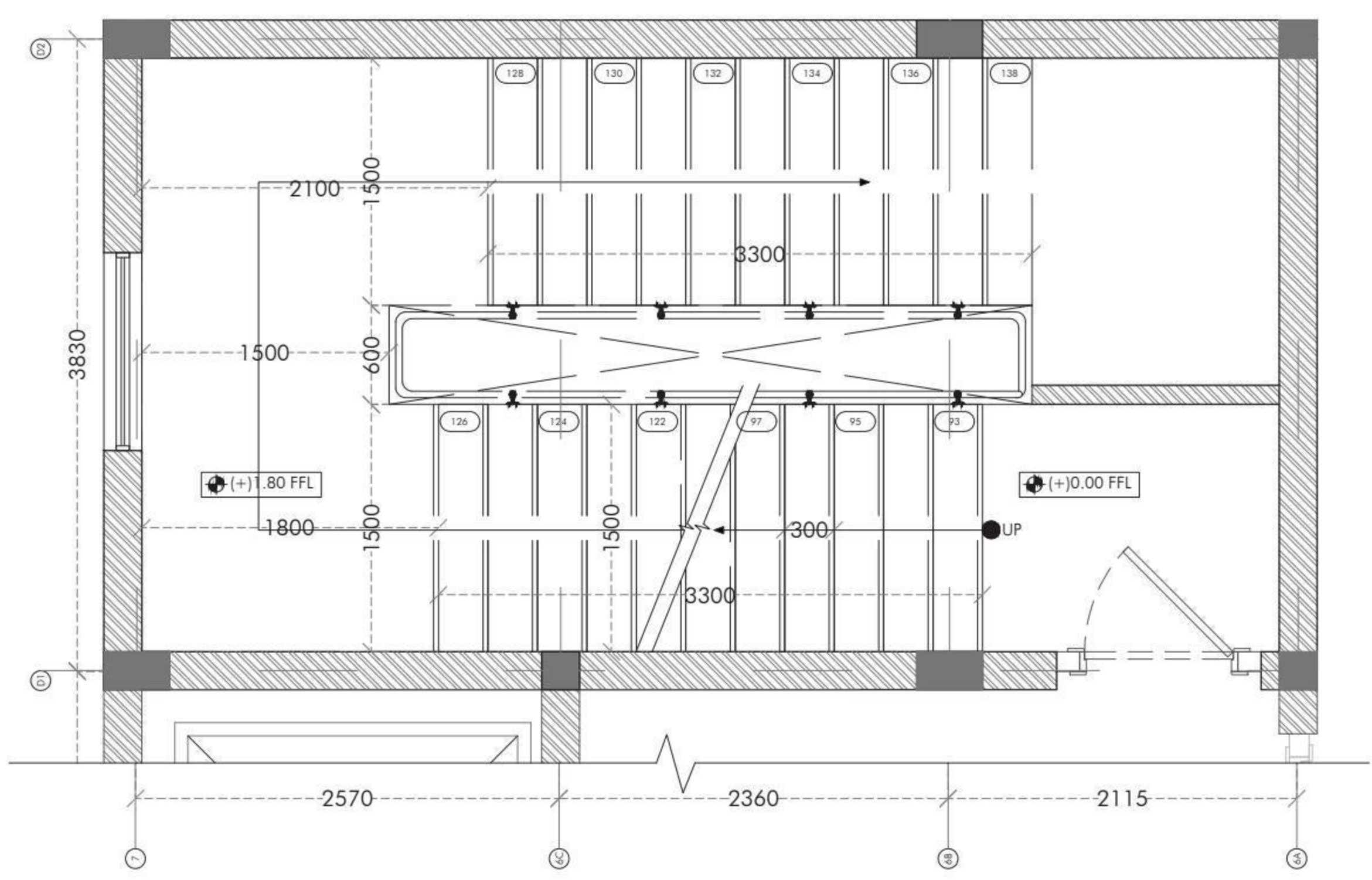
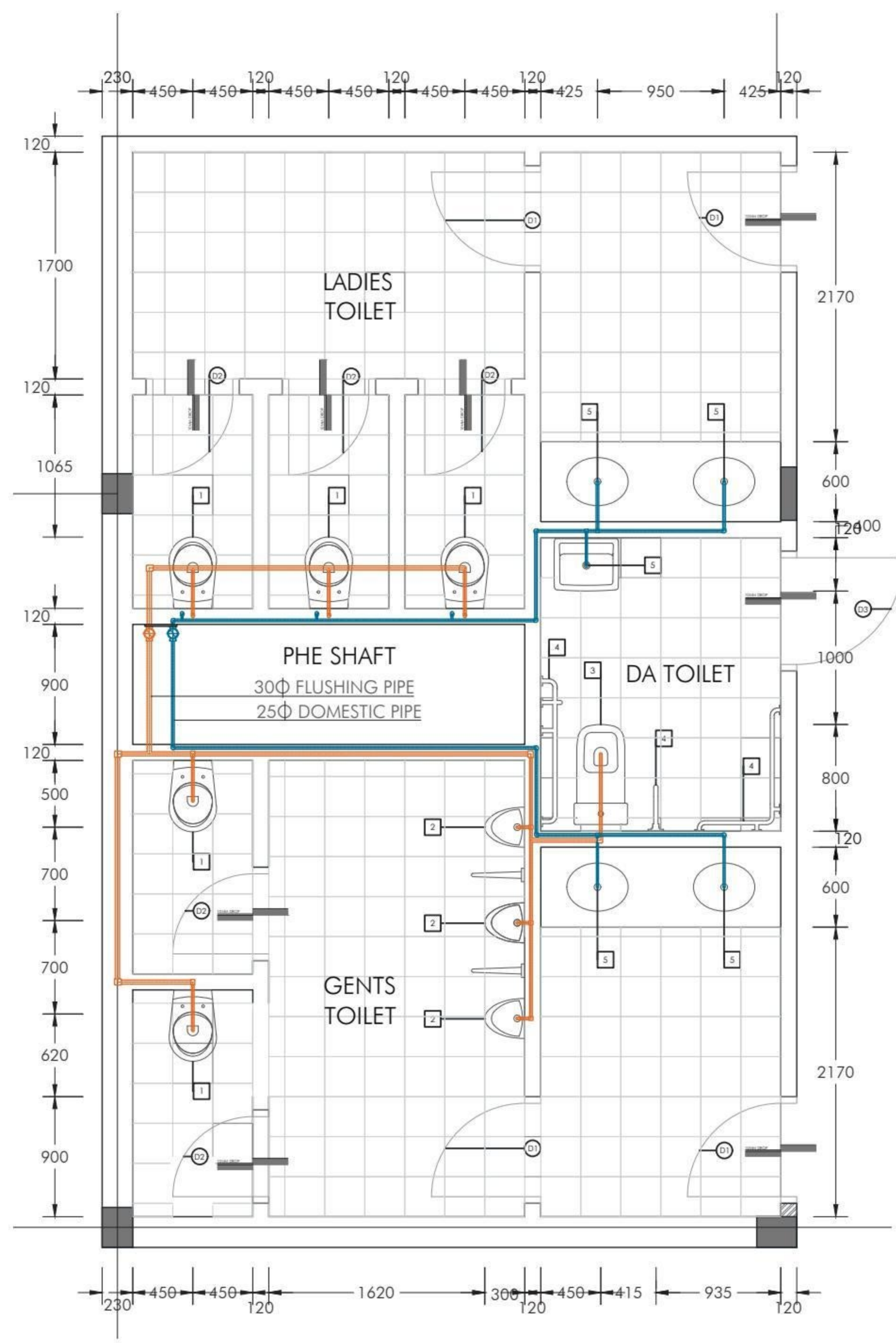

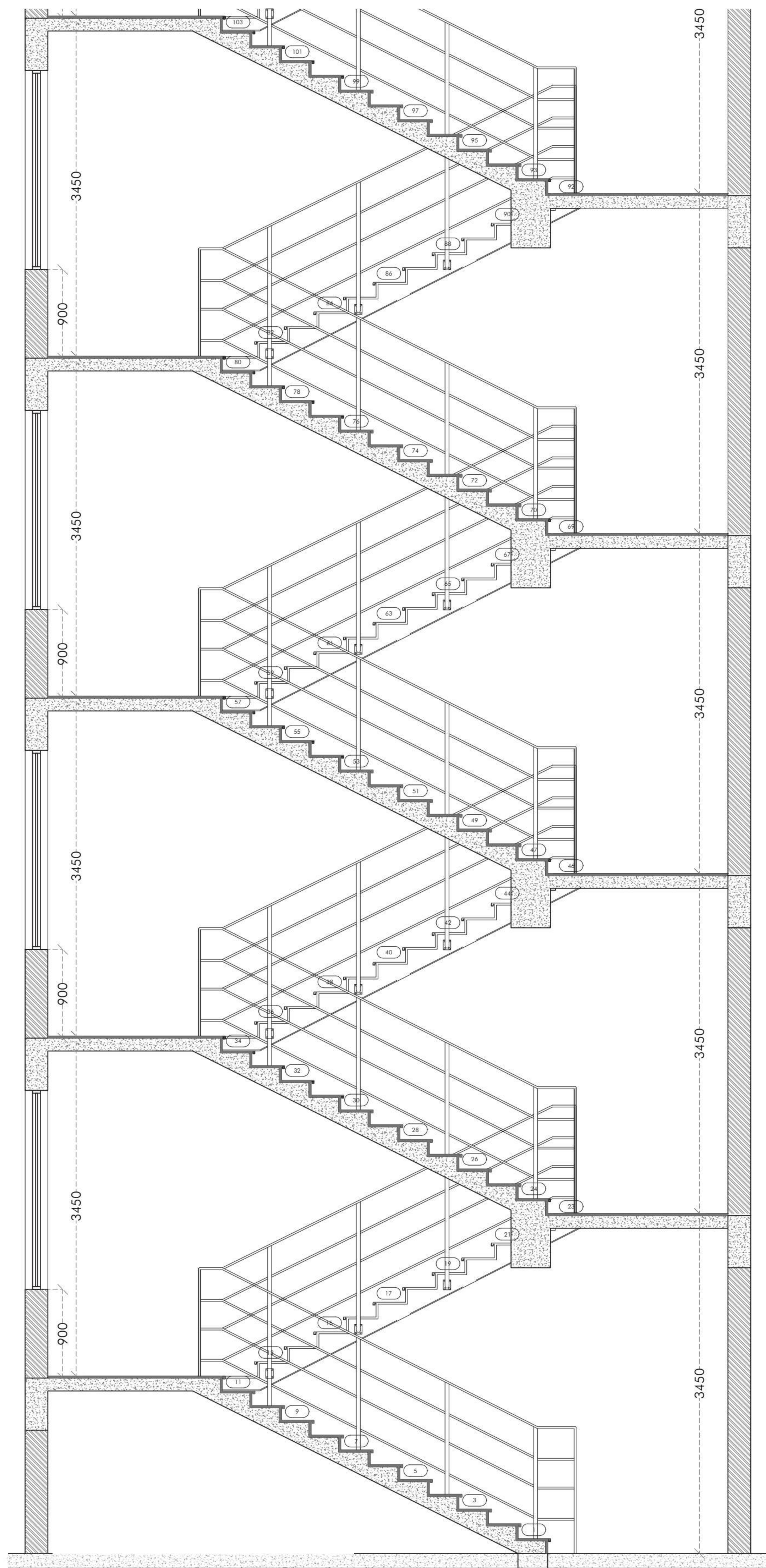
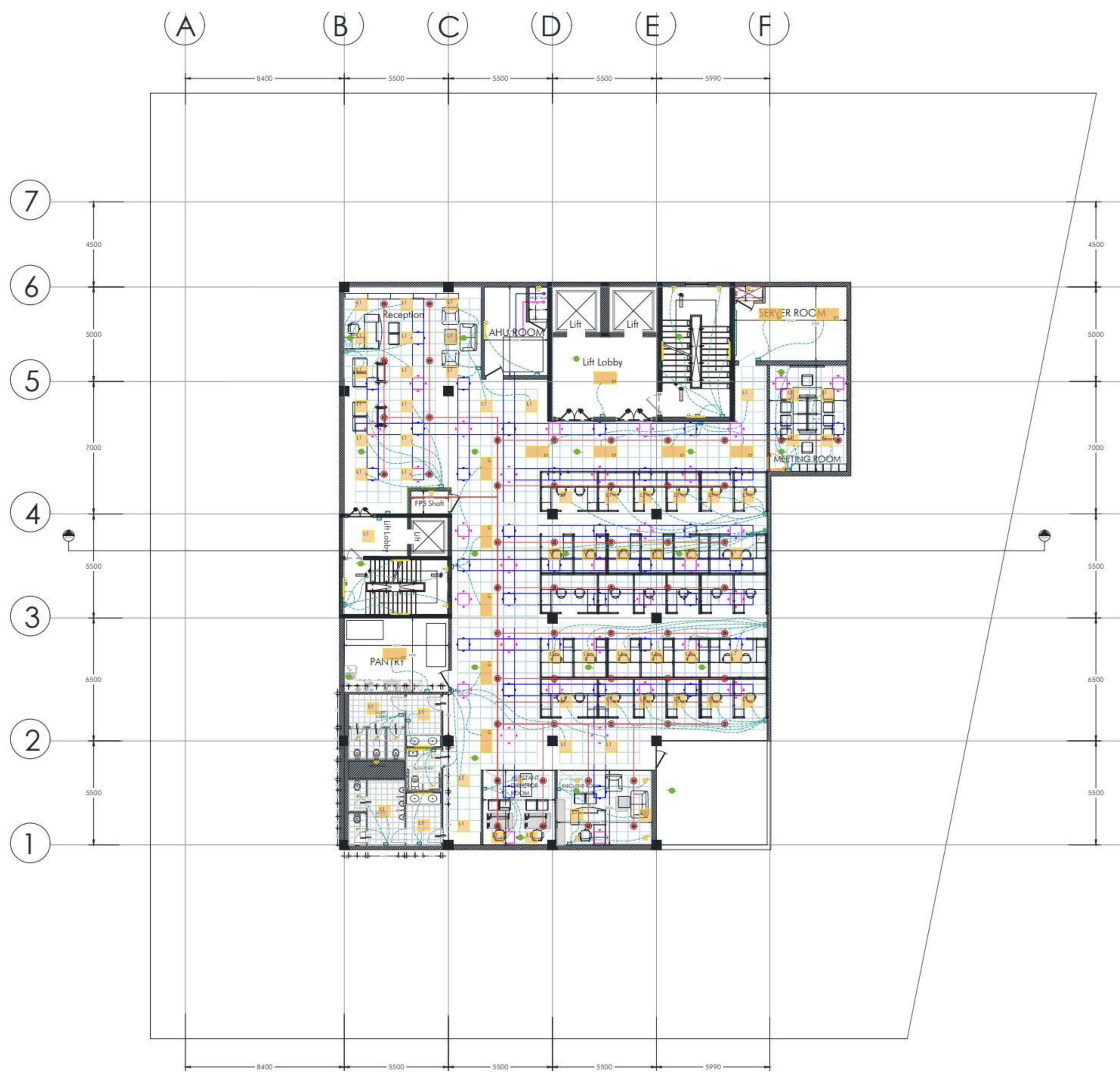

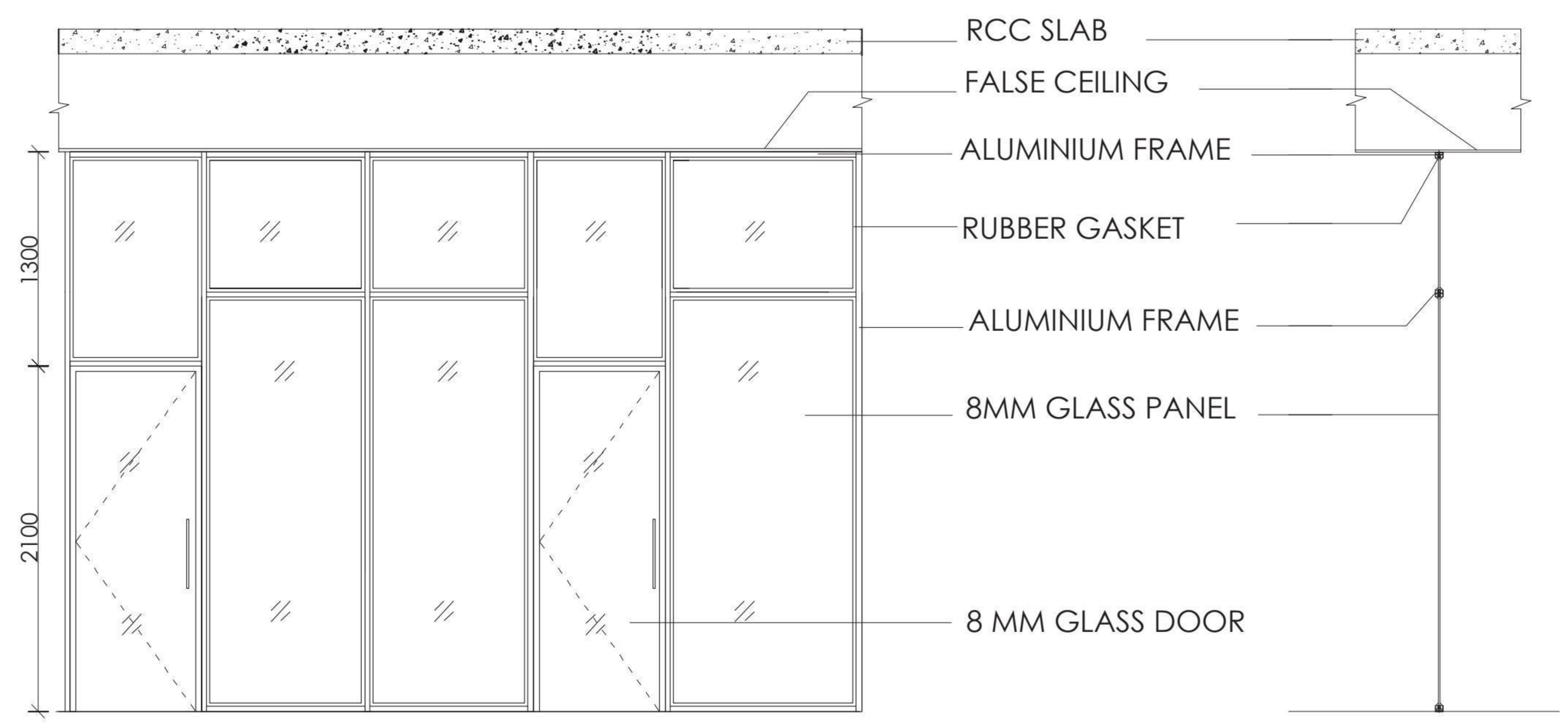
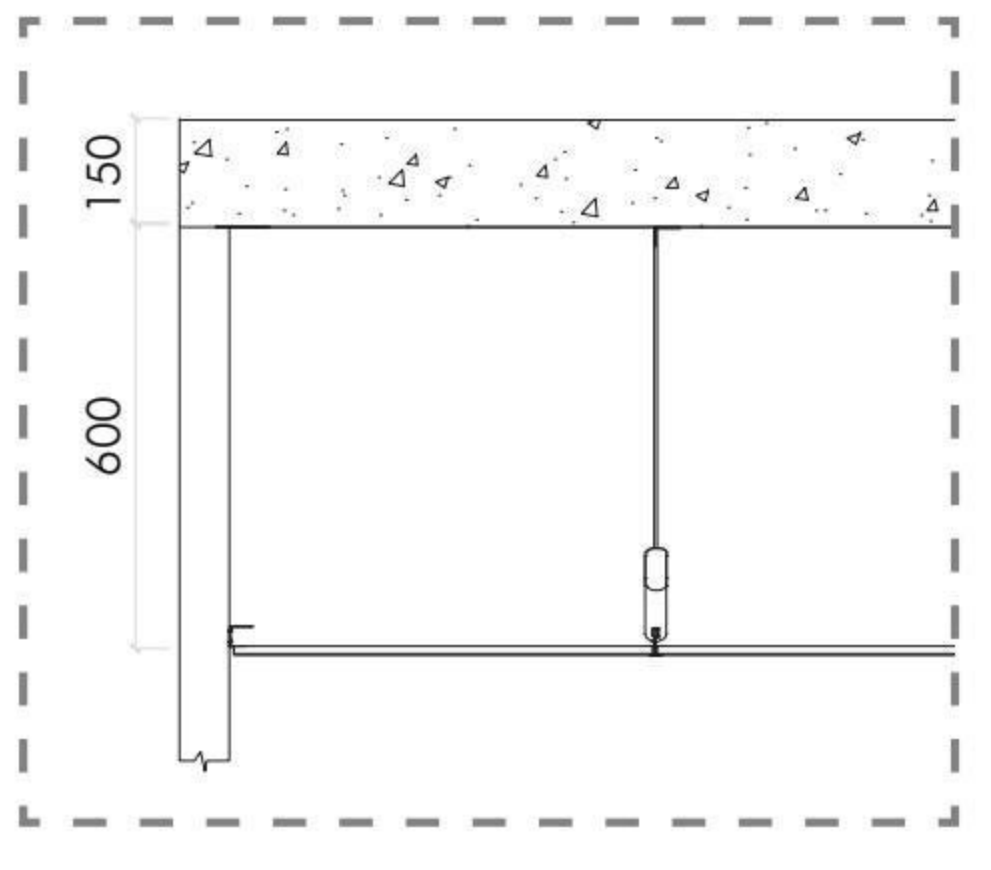
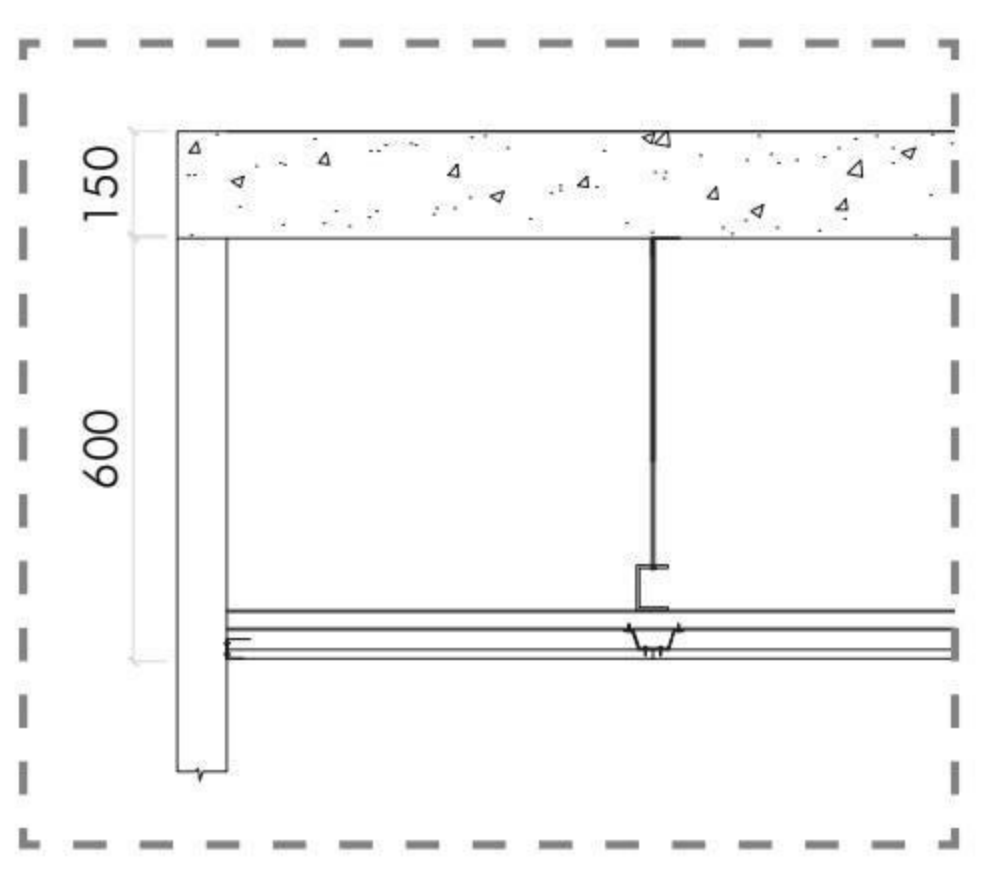
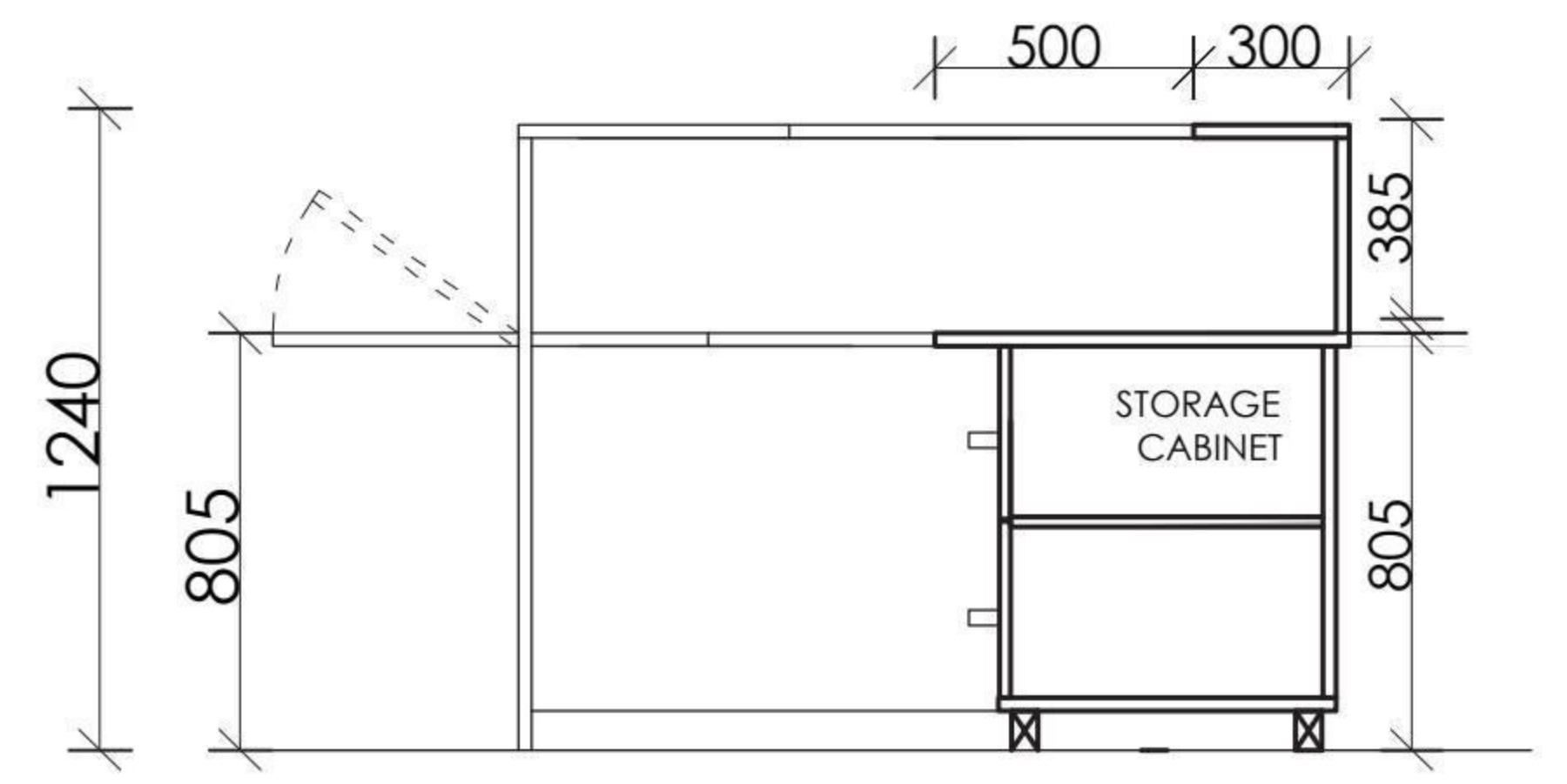
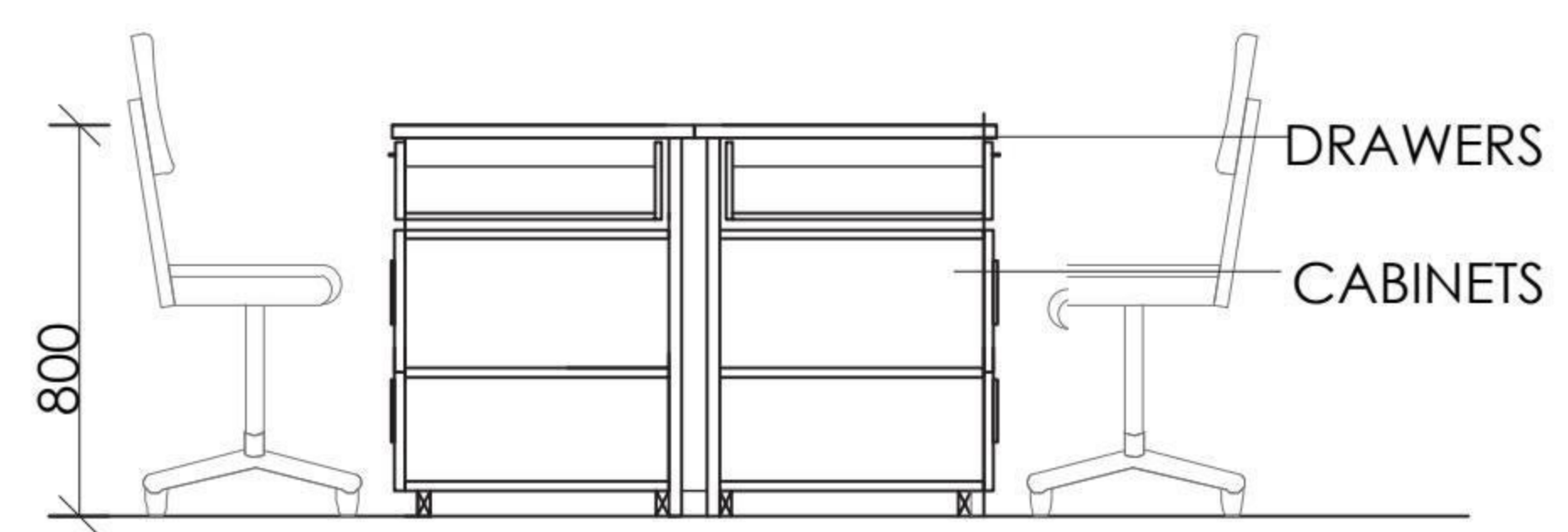
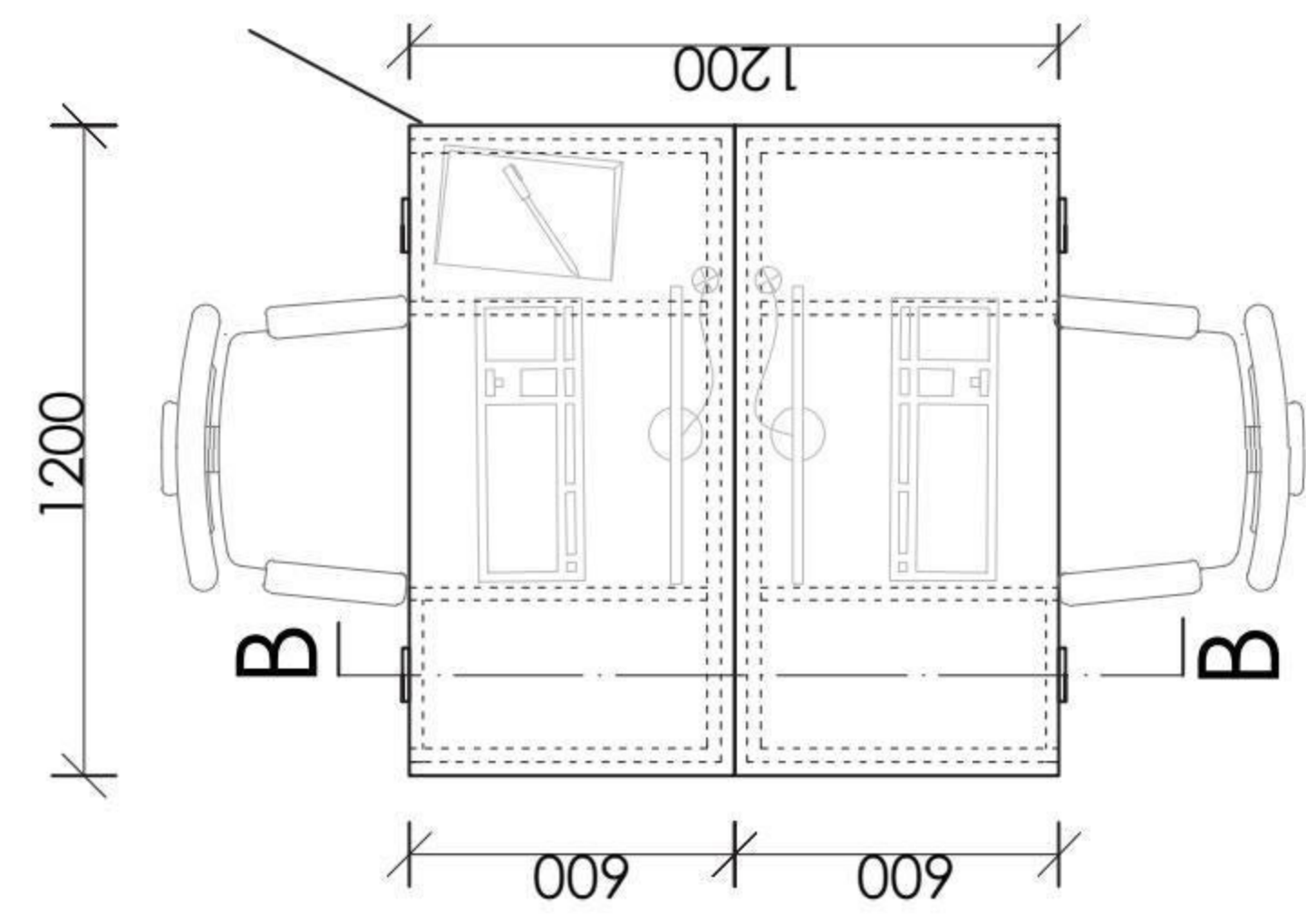
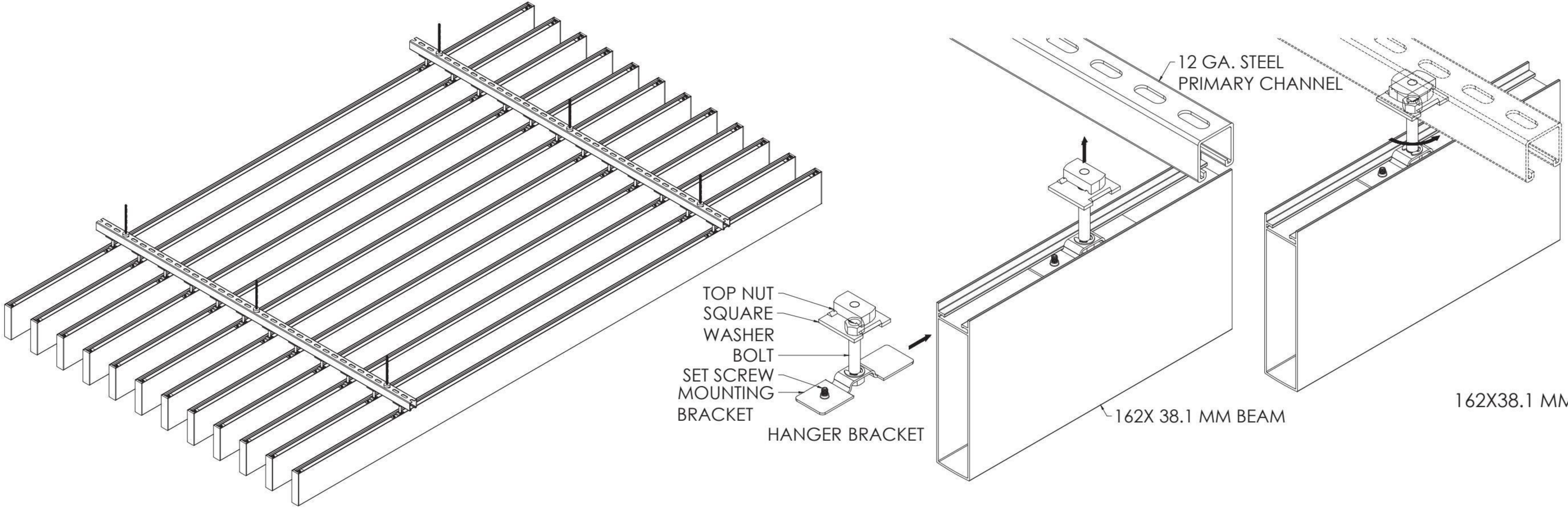



05

6 feet apart...

The concept of “SOCIAL DISTANCING” has its genesis in the pandemic known by different names, like COVID-19, SARS COVID etc., which shook the world into understanding and inventing ways and means, specially in the social arena, to prevent spread of the pandemic. While domestic front is managed by individuals/families, the responsibilities take steps on the social front, lies on the shoulders of one and all.

Architects, who specialise in designing structures to cater to the specific needs of their customer, are now required to extend their innovative skills to cater to social needs.





The entire idea is to create a place, which is wrapped around natural landscape in places like a park without any physical barriers separating them.



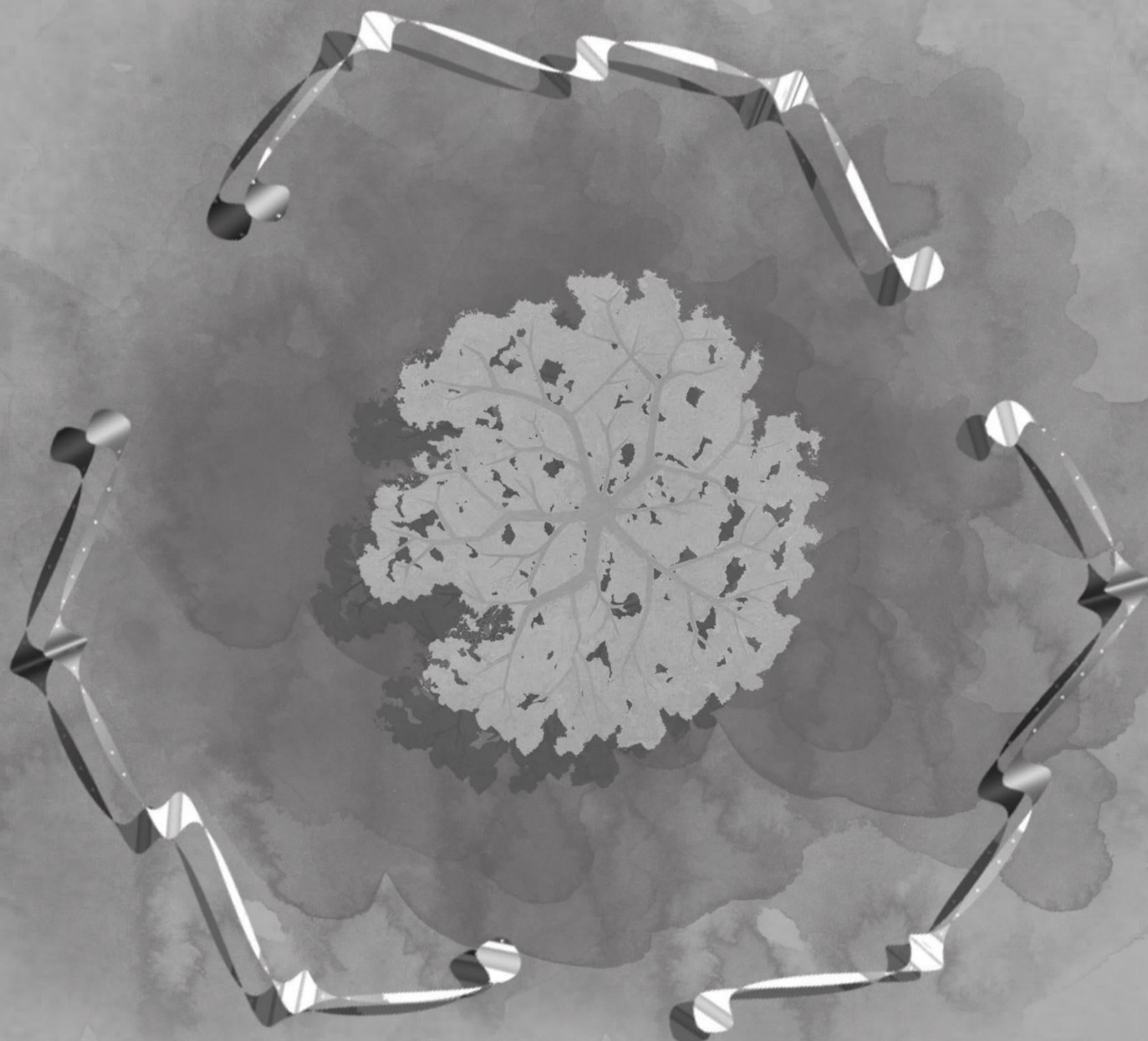

The design is a public seating structure which is an organic structure made in the form of a free flowing Sinusoidal Curve creating cliffs and depressions to maintain safe distance (1mt) between people both horizontally and vertically and also not give a physical barrier to lead them to isolation.

The material choice is steel rods for holding the structure and Aluminium Thin sheets for the seating curve. (Virus stays for 2 - 4 hours on these metals, so easy for sanitizing)

The free flowing curves wrap themselves around the natural landscape and create a central space for the performer and the people occupying the structure the spectators.



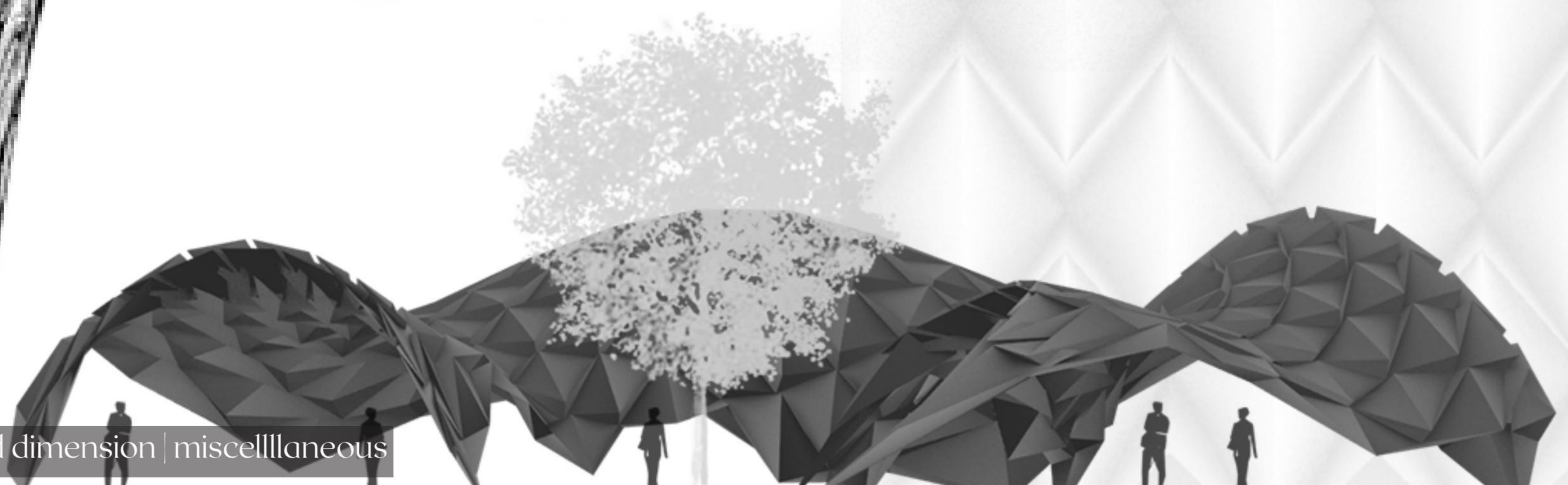

07

exploring the 3rd dimension

The directive put forward as a part of the digital architecture elective was to explore 3D Simulations using multiple softwares. The following models have been done in Rhino using grasshopper and other plug-ins associated with the same.

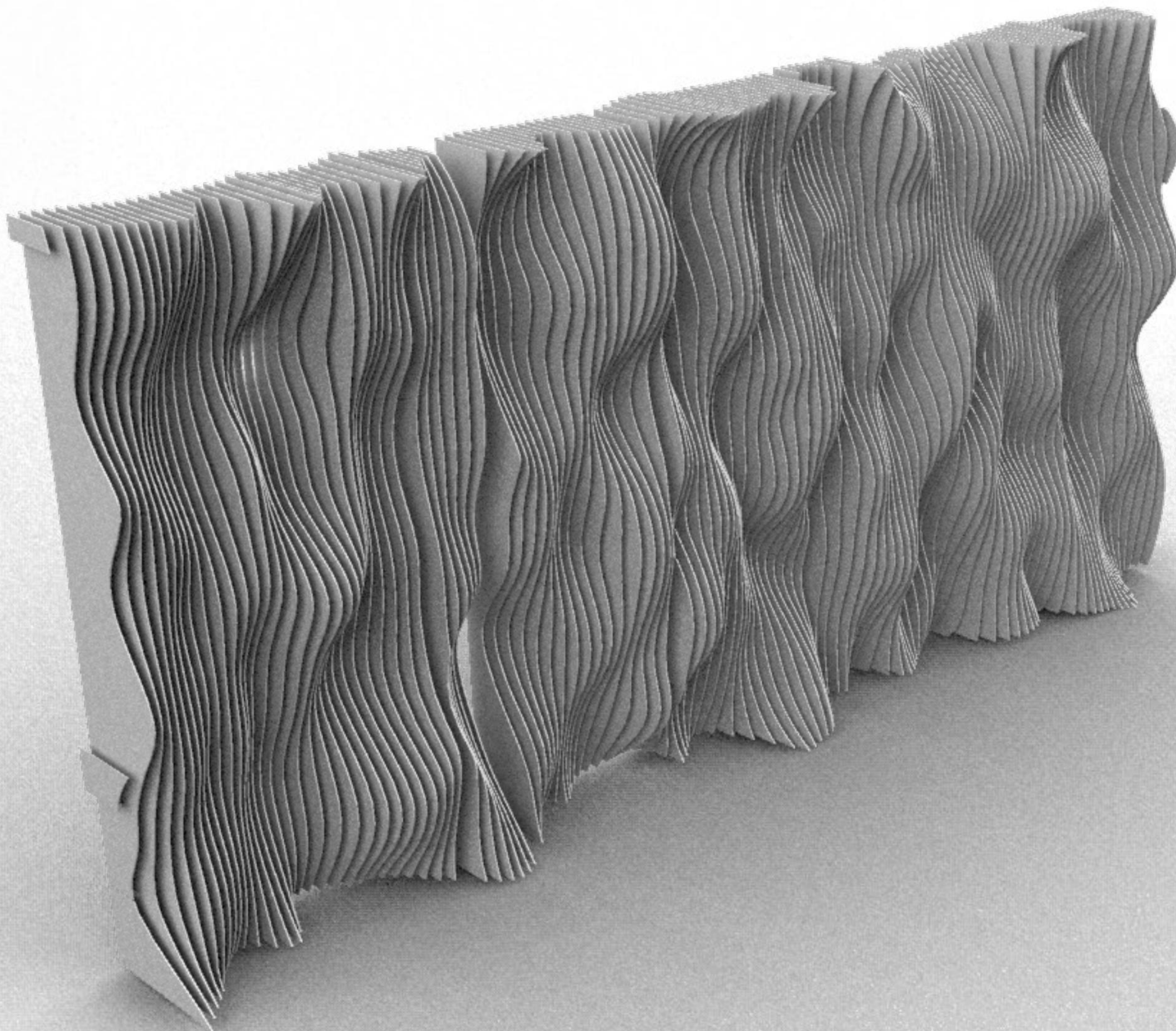



08

photographing memories

*Your birds of peace white-pinioned float
O'er ruined fort and storied plain,
Your faithful stewards sleepless guard
The harvests of your gold and grain.*

Sarojini Naidu, Ode To H.H. The Nizam Of Hyderabad





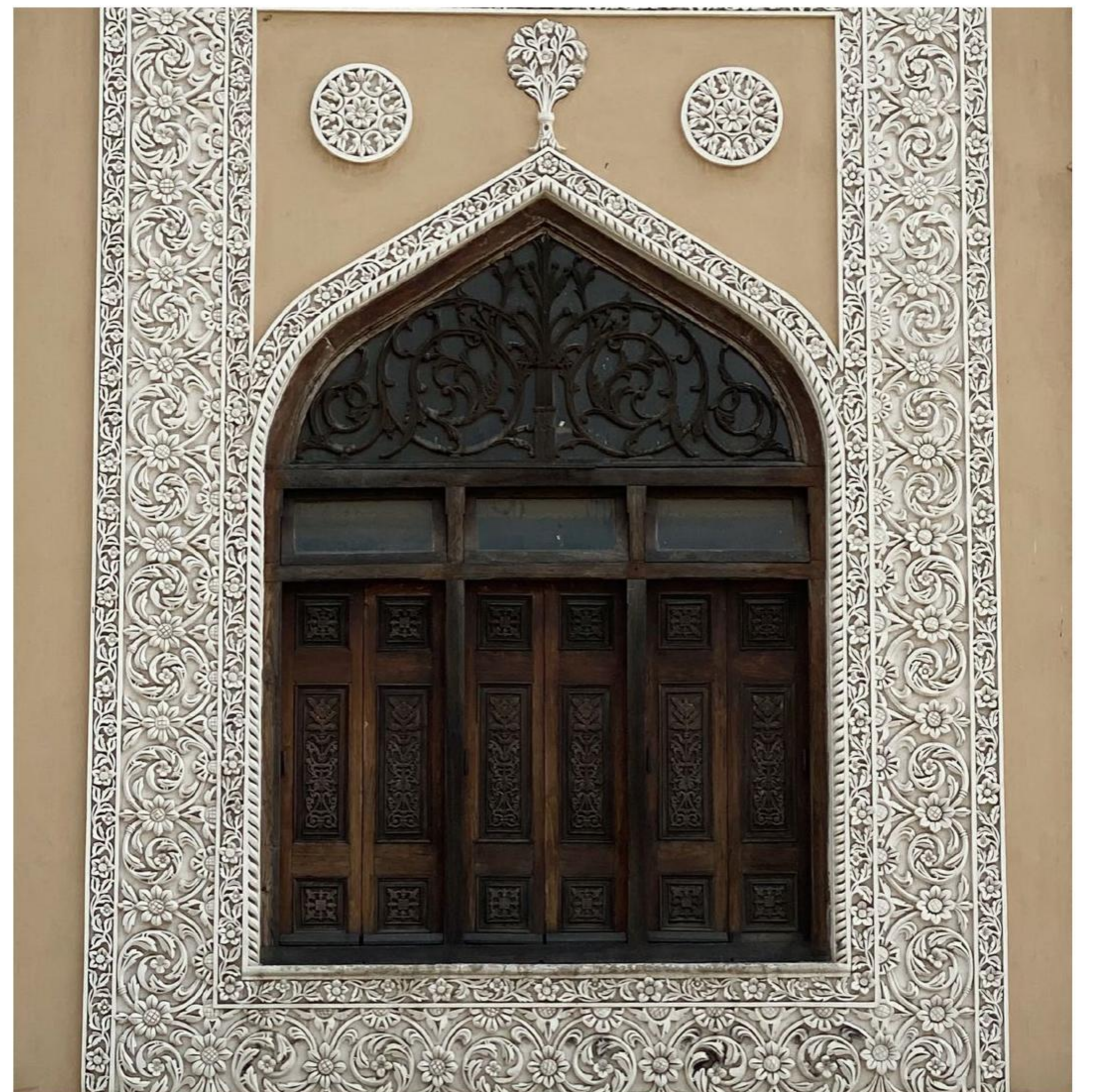
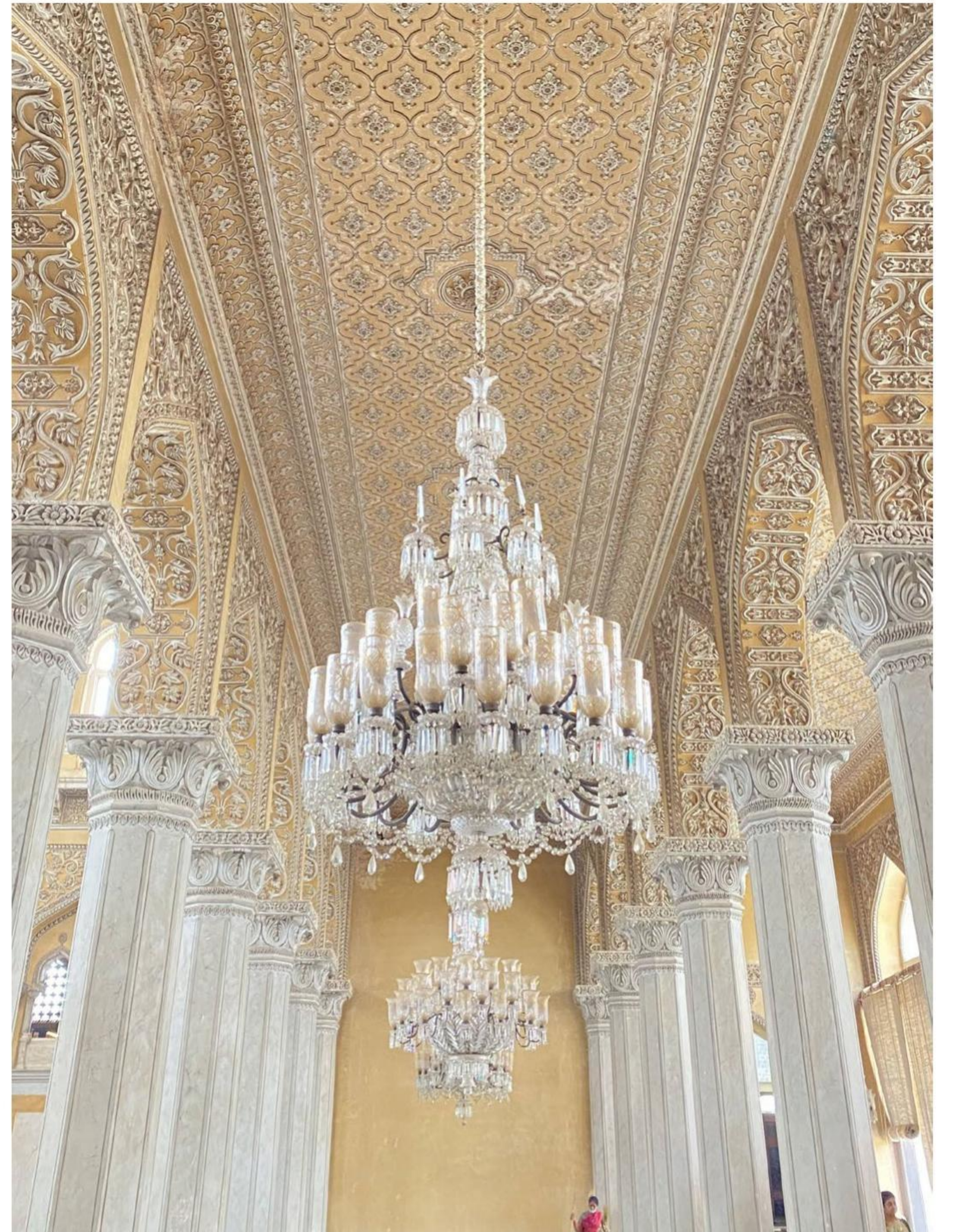

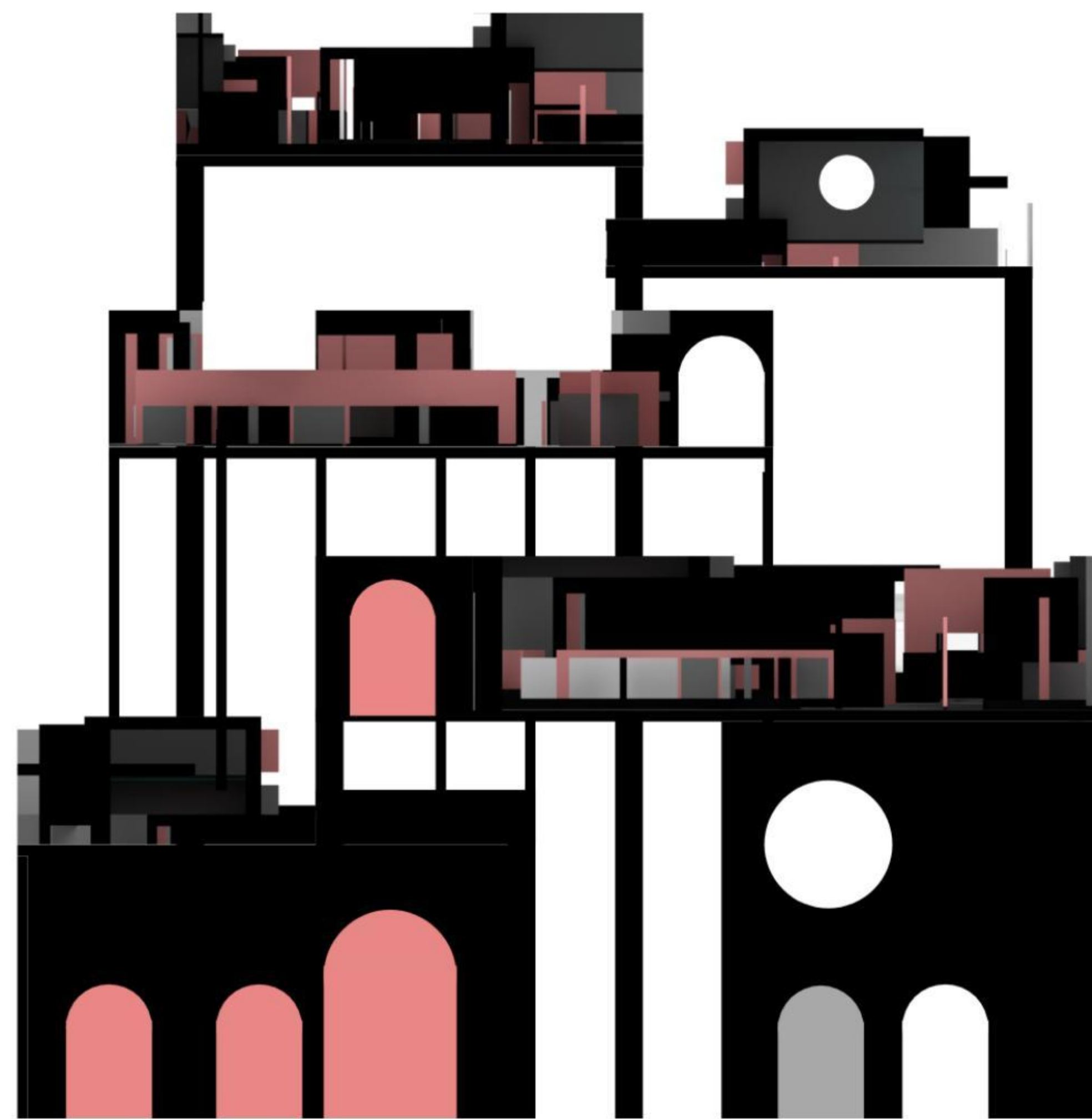
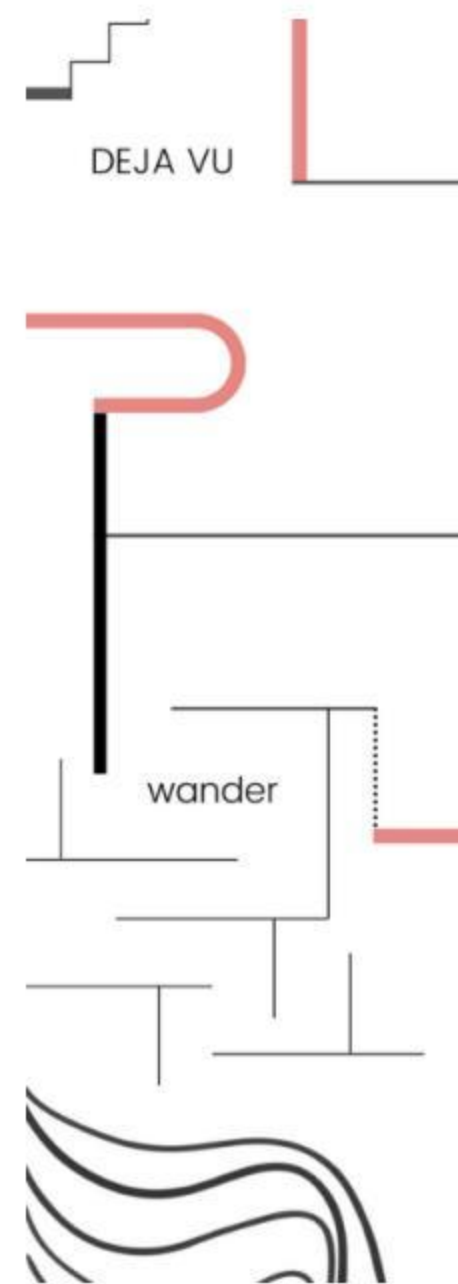
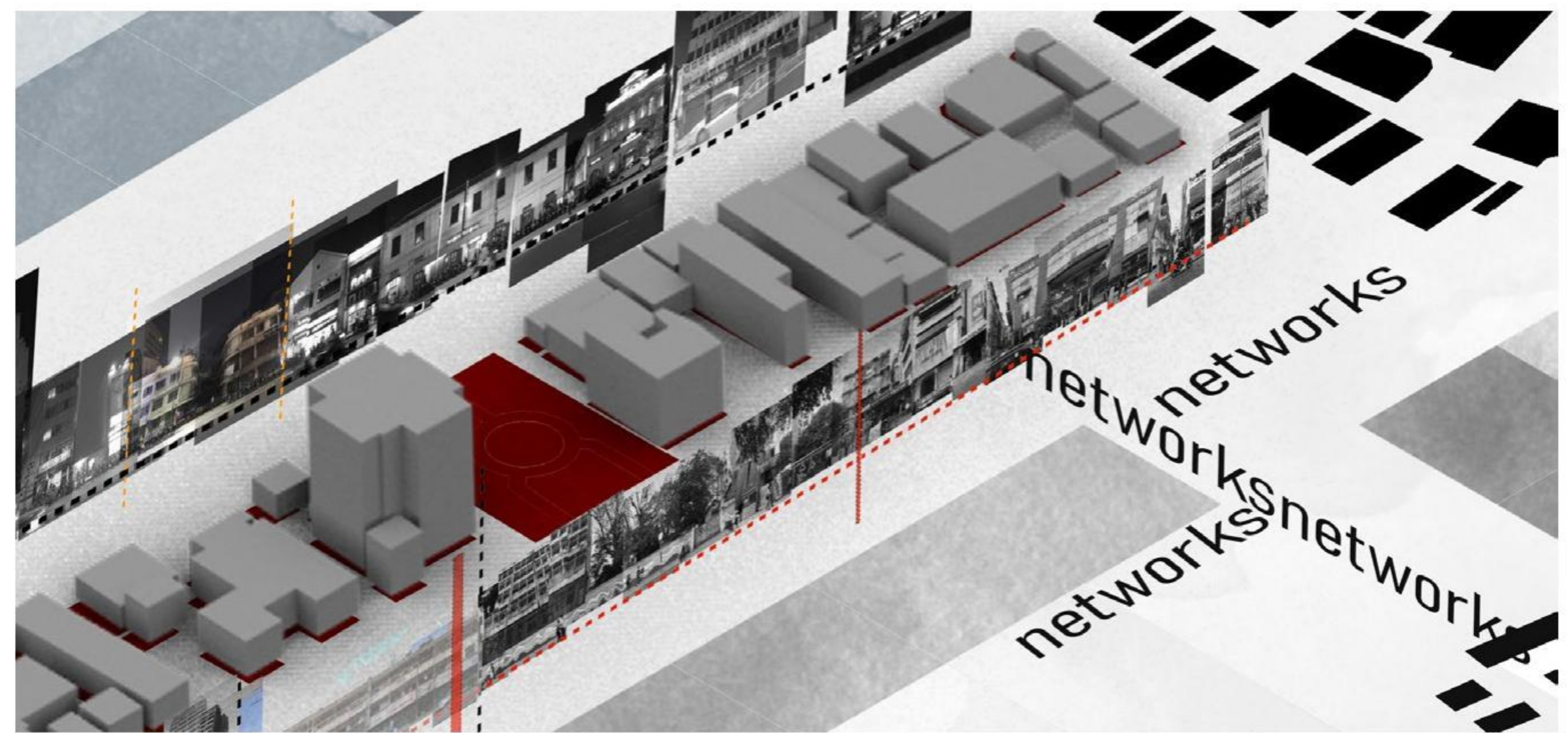
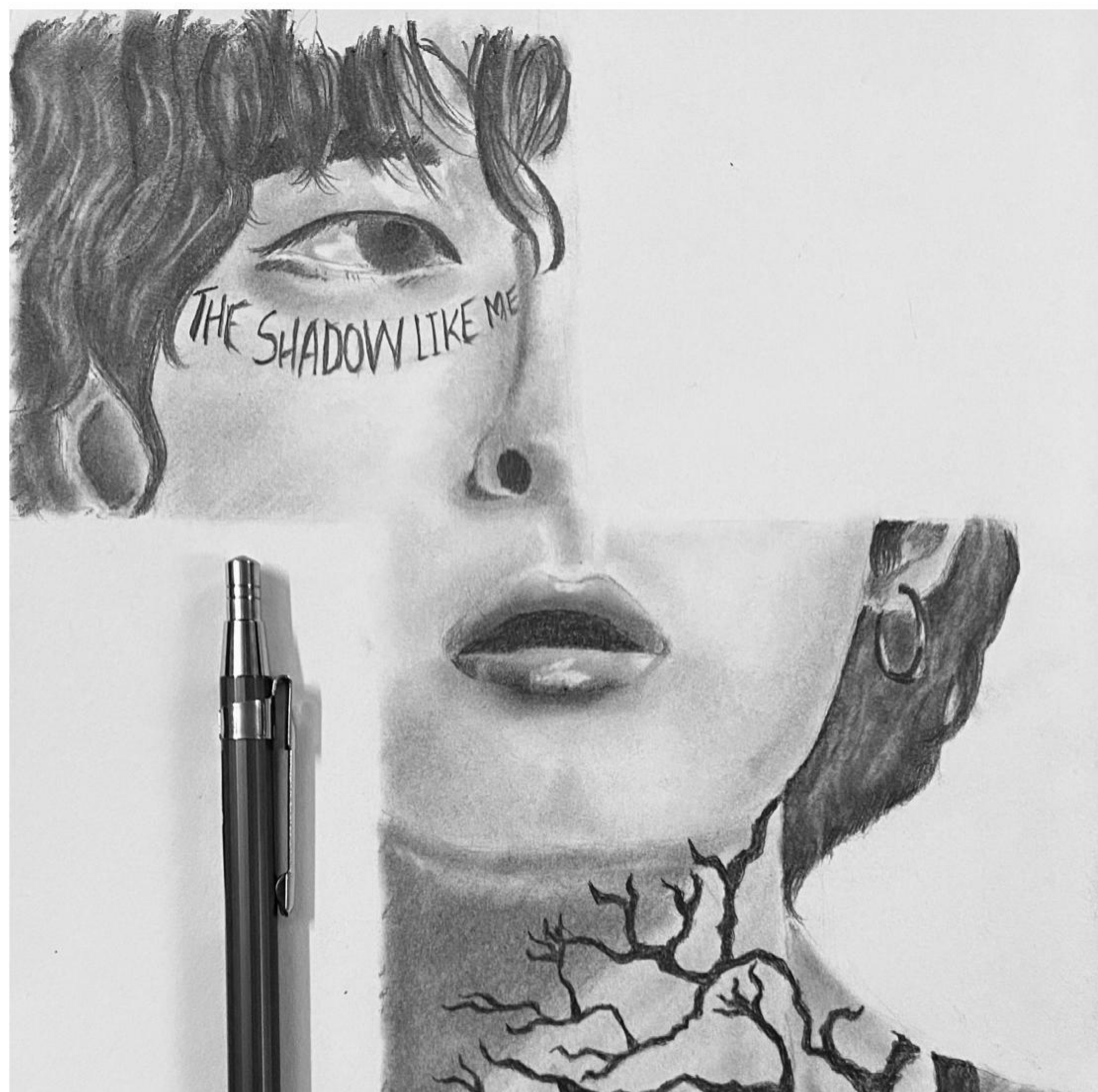
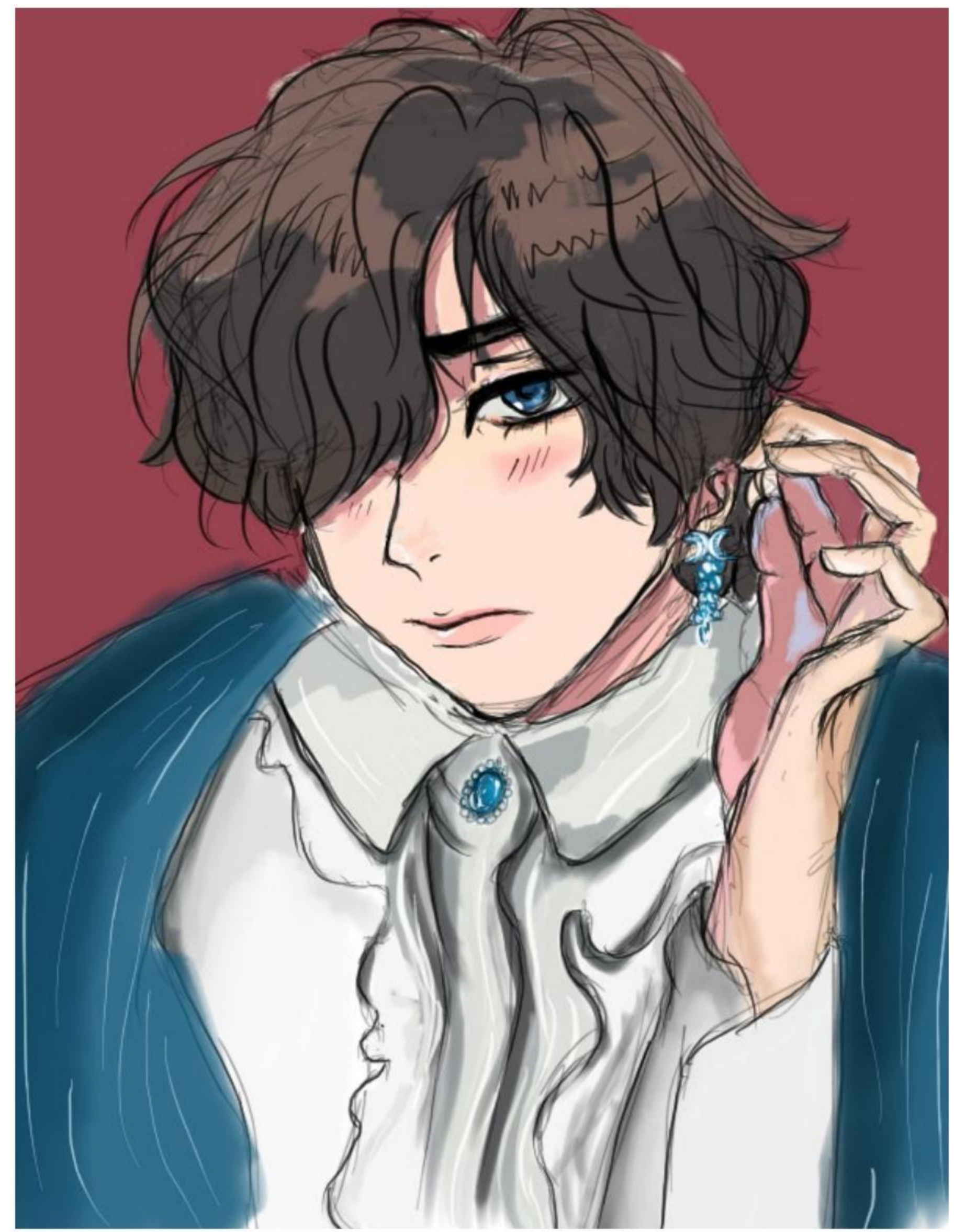
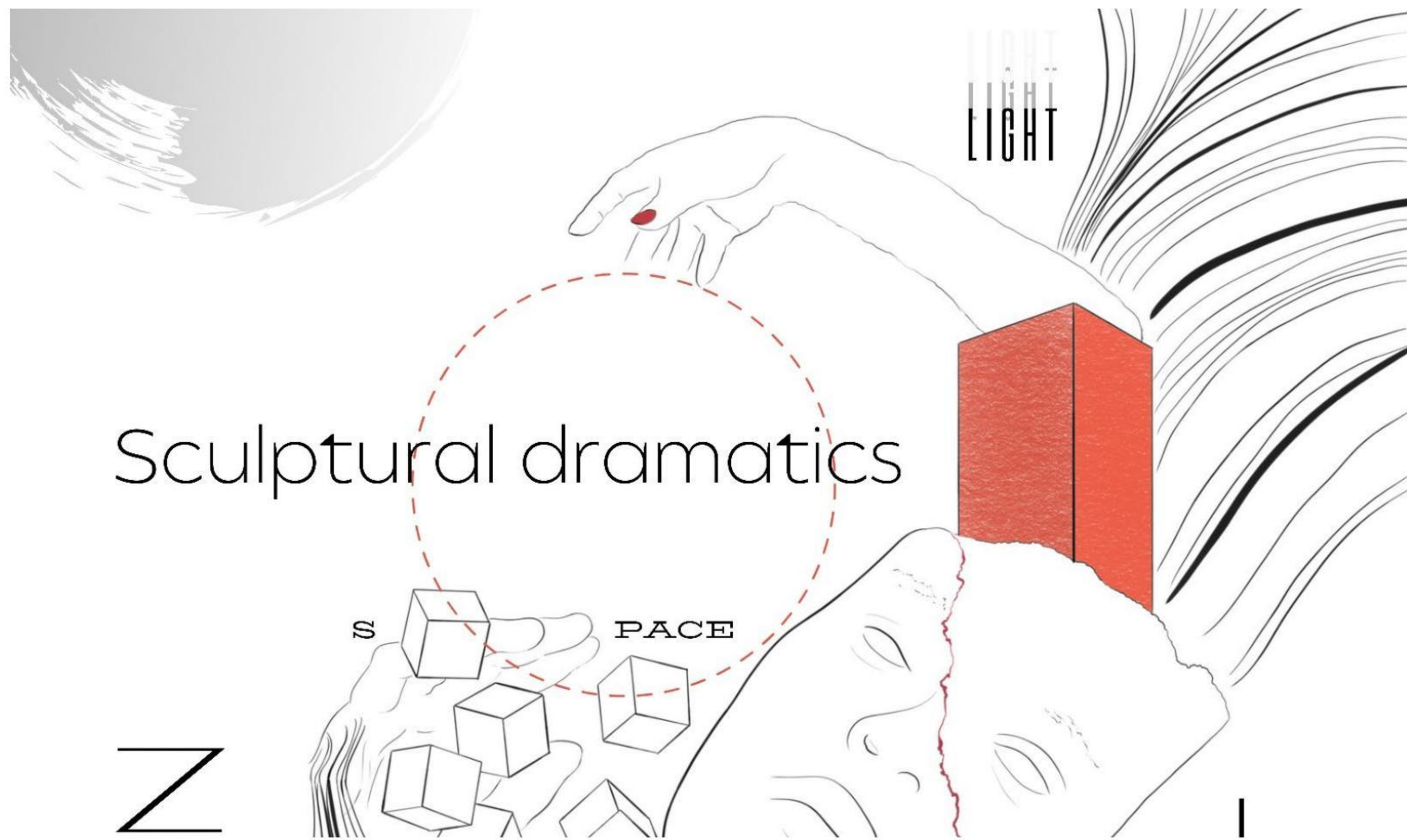

09

artworks

Visual Arts and poetry are spectacles of my architectural expression. The following are few works

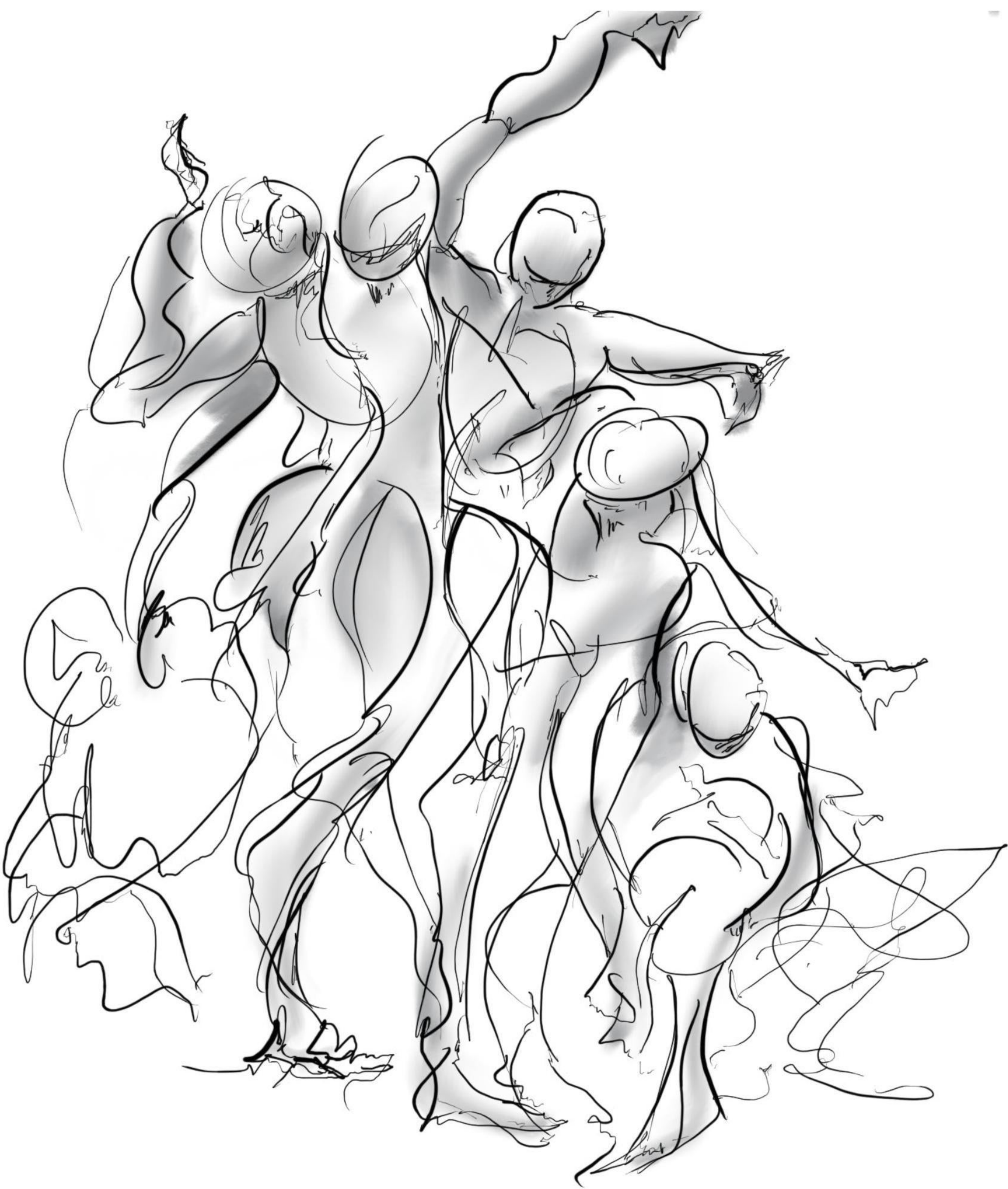
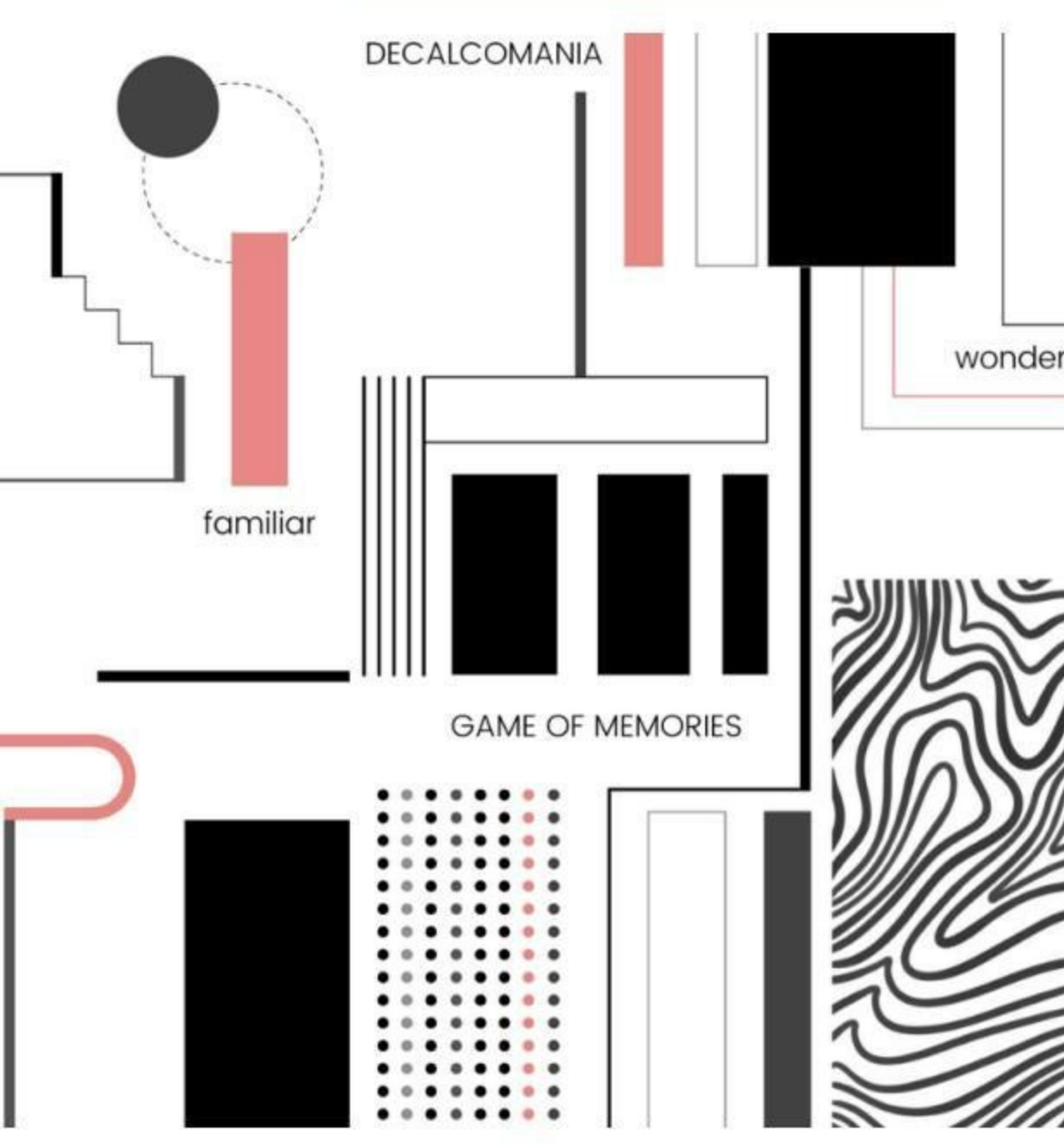

Take me back to those starry nights
Swirls and twists of nature Gogh could watch
Shining bright in the night sky
The moon and the stars in full bloom
While Adam rests and awaits for self
The fishes and octopuses dance and flap along the rhythm
Time is melting dear, Dali hangs in
While the flashes of the great wave
Carries her mighty Titanic
In the castle of dreams, we all await
Beyond the walls is not our fate
Holding on and letting go our dear ones we wait
Listening to the hymns of the mighty blue whale

Self poetry
26th September, 2020



*But I have promises to keep,
And miles to go before I sleep,
And miles to go before I sleep.*

Robert Frost, "Stopping by Woods on a Snowy Evening" from The Poetry of Robert Frost

This portfolio is solely created for the purpose of application of internship in architectural firms. All works are carried out by Koduri Nagasrivatsa, unless mentioned otherwise.